



LINKSYS[®]
A Division of Cisco Systems, Inc.
17401 Armstrong Ave.,
Irvine, CA 92614

Linksys PAP2 and RT31P2

PHONE ADAPTER Administration Guide

August 2004

Disclaimer – Please Read:

This document contains implementation examples and techniques using Linksys and, in some instances, other company's technology and products and is a recommendation only and does not constitute any legal arrangement between Linksys and the reader, either written or implied. The conclusions reached and recommendations and statements made are based on generic network, service and application requirements and should be regarded as a guide to assist you in forming your own opinions and decision regarding your particular situation. As well, Linksys Technology reserves the right to change the features and functionalities for products described in this document at any time. These changes may involve changes to the described solutions over time.

Use of Proprietary Information and Copyright Notice:

Major portions of this document are the sole property of Sipura Technology, Inc. and are provided to its licensee, Linksys LLC., and protected by United States and international copyright laws. (c)2003-2004 Sipura technology, Inc. - All rights reserved.

Table of Contents

1.	Introduction	6
1.1.	The Session Initiation Protocol	6
1.1.1.	Components of a SIP Network	8
1.1.2.	Provisioning Overview	9
1.1.3.	Security Overview.....	10
1.1.3.1.	Proxy Servers	11
1.1.4.	SIP Services.....	11
1.1.4.1.	Basic Services	12
1.1.4.2.	Enhanced Services.....	12
1.1.4.3.	PSTN Interworking.....	14
1.2.	Network Address Translation (NAT) Traversal.....	15
1.2.1.	What is a NAT or NAT (Network Address Port Translator)?	15
1.2.2.	VoIP-NAT Interworking.....	16
1.3.	Voice Quality Overview	16
2.	Hardware Overview	17
2.1.	Phone Adapter LED Status	19
2.2.	Broadband Router (RT31P2) LED Status	19
3.	Software Configuration Mechanisms.....	20
3.1.	Configuration Profile Formats.....	21
3.1.1.	Using the Supplemental Profile Compiler.....	23
3.1.2.	Encrypting and Compressing XML configuration files	24
3.2.	Secure Initial Configuration	25
3.3.	Web Interface	26
3.3.1.	Web Interface Conventions	26
3.3.2.	Administration Privileges	27
3.3.3.	Basic and Advanced Views	27
3.4.	Functional Configuration URLs.....	27
3.4.1.	Upgrade URL	27
3.4.2.	Resync URL	28
3.4.3.	Reboot URL.....	28
3.5.	Configuration via the IVR (PAP2 only)	29
4.	Configuration Parameters.....	32
4.1.	Data Types	32
4.1.1.	Conventions	35
4.2.	Provisioning Related Parameters	35
4.2.1.	Firmware Upgrade.....	43
4.2.2.	Provisioning Server Redundancy	46
4.2.3.	Configuring the Web Server and IVR	46
	System Configuration	46
4.3.	Basic Networking Configuration.....	47
	Network Configuration	47
4.4.	Basic Account Configuration	48
4.5.	Configuration for NAT Traversal	49
4.6.	Media and SDP (Session Description Protocol) Configuration.....	51
4.6.1.	DTMF and Hookflash.....	51
4.6.2.	Codec and Audio Settings	52
4.6.3.	Dynamic Payload Types and SDP Codec Names.....	53
4.6.4.	Secure Media Implementation:.....	54
4.6.5.	Outbound Call Codec Selection Codes:	56
4.7.	Supplementary Services	57
4.7.1.	Supplementary Services activated internally	58
4.7.2.	Call Forwarding Implemented internally	60
4.7.3.	Supplementary Services implemented in the service provider network.....	60
4.8.	Dial Plan Configuration.....	61
4.8.1.	Speed Dialing Settings	66

4.9.	Progress Tone and Ring Configuration.....	67
4.9.1.	Distinctive Ring and Other Ring Settings.....	67
4.9.2.	Progress Tones.....	69
4.10.	Less Frequently Used Paramters.....	70
4.10.1.	Advanced Protocol Parameters.....	70
4.10.2.	Additional User Account Information.....	73
4.10.3.	Per-Line Polarity Settings.....	75
4.10.4.	Additional Timer Values (sec).....	75
4.10.5.	Miscellaneous Parameters.....	76
5.	Expected Feature Behavior.....	79
5.1.	Originating a Phone Call.....	79
5.2.	Receiving a Phone Call.....	79
5.3.	Caller ID.....	80
5.4.	Calling Line Identification Presentation (CLIP).....	80
5.5.	Calling Line Identification Restriction (CLIR) – Caller ID Blocking.....	81
5.6.	Call Waiting.....	81
5.7.	Disable or Cancel Call Waiting.....	82
5.8.	Call-Waiting with Caller ID.....	83
5.9.	Voice Mail.....	83
5.10.	Attendant Call Transfer.....	84
5.11.	Unattended or “Blind” Call Transfer.....	85
5.12.	Call Hold.....	85
5.13.	Three-Way Calling.....	86
5.14.	Three-Way Ad-Hoc Conference Calling.....	86
5.15.	Call Return.....	87
5.16.	Automatic Call Back.....	87
5.17.	Call FWD – Unconditional.....	88
5.18.	Call FWD – Busy.....	89
5.19.	Call FWD - No Answer.....	89
5.20.	Anonymous Call Blocking.....	90
5.21.	Distinctive / Priority Ringing and Call Waiting Tone.....	90
5.22.	Speed Calling – Up to Eight (8) Numbers or IP Addresses.....	91
6.	Troubleshooting.....	92
6.1.	Call Statistics Reporting.....	92
6.2.	Enabling Logging and Debugging.....	93
6.3.	Error and Log Reporting.....	93
6.4.	Internal Error Codes.....	93
6.5.	Provisioning and Upgrade result codes.....	94
6.6.	Table of SIP Response Codes (Error Codes).....	94
7.	Summary of Implemented Features and Specifications.....	95
7.1.	Data Networking Features.....	95
7.1.1.	MAC Address (IEEE 802.3).....	95
7.1.2.	IPv4 – Internet Protocol Version 4 (RFC 791) upgradeable to v6 (RFC 1883).....	96
7.1.3.	ARP – Address Resolution Protocol.....	96
7.1.4.	DNS – A Record (RFC 1706), SRV Record (RFC 2782).....	96
7.1.5.	DiffServ (RFC 2475) and ToS – Type of Service (RFC 791/1349).....	96
7.1.6.	DHCP Client – Dynamic Host Configuration Protocol (RFC 2131).....	96
7.1.7.	ICMP – Internet Control Message Protocol (RFC792).....	96
7.1.8.	TCP – Transmission Control Protocol (RFC793).....	96
7.1.9.	UDP – User Datagram Protocol (RFC768).....	96
7.1.10.	RTP – Real Time Protocol (RFC 1889) (RFC 1890).....	96
7.1.11.	RTCP – Real Time Control Protocol (RFC 1889).....	96
7.2.	Voice Features.....	96
7.2.1.	SIPv2 – Session Initiation Protocol Version 2 (RFC 3261-3265).....	96
7.2.1.1.	SIP Proxy Redundancy – Static or Dynamic via DNS SRV.....	96
7.2.1.2.	Re-registration with Primary SIP Proxy Server.....	96

7.2.1.3.	SIP Support in Network Address Translation Networks – NAT	96
7.2.2.	Codec Name Assignment.....	96
7.2.3.	Secure Calls	97
7.2.4.	Voice Algorithms:	97
7.2.4.1.	G.711 (A-law and μ -law)	97
7.2.4.2.	G.726	97
7.2.4.3.	G.729A.....	97
7.2.4.4.	G.723.1	97
7.2.5.	Codec Selection	97
7.2.6.	Dynamic Payload	97
7.2.7.	Adjustable Audio Frames Per Packet.....	97
7.2.8.	Fax Tone Detection Pass-Through.....	97
7.2.9.	DTMF: In-band & Out-of-Band (RFC 2833) (SIP INFO *).....	97
7.2.10.	Call Progress Tone Generation	98
7.2.11.	Call Progress Tone Pass Through.....	98
7.2.12.	Jitter Buffer – Dynamic (Adaptive)	98
7.2.13.	Full Duplex Audio.....	98
7.2.14.	Echo Cancellation – Up to 8 ms Echo Tail.....	98
7.2.15.	Voice Activity Detection with Silence Suppression & Comfort Noise Generation	98
7.2.16.	Attenuation / Gain Adjustment	98
7.2.17.	Signaling Hook Flash Event.....	98
7.2.18.	Configurable Flash / Switch Hook Timer.....	99
7.2.19.	Configurable Dial Plan with Interdigit Timers	99
7.2.20.	Message Waiting Indicator Tones – MWI	99
7.2.21.	Polarity Control	99
7.2.22.	Calling Party Control – CPC	99
7.2.23.	International Caller ID Delivery	99
7.2.24.	Streaming Audio Server – SAS	100
7.2.25.	Music On Hold – MOH.....	100
7.3.	Security Features.....	102
7.3.1.	Multiple Administration Layers (Levels and Permissions).....	102
7.3.2.	HTTP Digest – Encrypted Authentication via MD5 (RFC 1321)	102
7.3.3.	HTTPS with Client Certificate	102
7.4.	Administration and Maintenance Features	102
7.4.1.	Web Browser Administration and Configuration via Integral Web Server.....	102
7.4.2.	Telephone Key Pad Configuration with Interactive Voice Prompts.....	102
7.4.3.	Automated Provisioning & Upgrade via TFTP, HTTP and HTTPS	102
7.4.4.	Periodic Notification of Upgrade Availability via NOTIFY or HTTP	102
7.4.5.	Non-Intrusive, In-Service Upgrades	102
7.4.6.	Report Generation and Event Logging	102
7.4.7.	Syslog and Debug Server Records	102
8.	List of all configuration parameters	102
9.	Acronyms	113
10.	Glossary.....	115

1. Introduction

This guide describes basic administration and use of the Linksys Technology PHONE ADAPTER phone adapter – an intelligent low-density Voice over IP (VoIP) gateway. The PHONE ADAPTER enables carrier class residential and business IP Telephony services delivered over broadband or high-speed Internet connections. By intelligent, we mean the PHONE ADAPTER maintains the states of all the calls it terminates. It is capable of making proper decisions in reaction to user input events (such as on/off hook or hook flash) with little or no involvement by a ‘middle-man’ server or media gateway controller.

Examples of proper reactions are: playing dial tone, collecting DTMF digits, comparing them against a dial plan and terminating a call. With intelligent endpoints at the edges of a network, performing the bulk of the call processing duties, the deployment of a large network with thousands of subscribers can scale quickly without the introduction of complicated, expensive servers. As described later in this section, the Session Initiation Protocol (SIP) is a good choice of call signaling protocol for the implementation of such a device in this type of network.

The phenomenal growth of broadband Internet access (DSL, Cable, FTTH, etc.), has brought the realization of reliable packet switched IP Telephony Services with circuit switched toll-quality and subscriber feature transparency with that of the PSTN's CLASS feature-set. In addition to basic offerings comparable to traditional PSTN services, many service providers have integrated their IP Telephony offering with a large number of web-based productivity applications like unified messaging and call management features such as, remote call forward configuration via the web. Such advances over traditional phone services, with equal or better voice quality and lower per-minute prices, have made IP Telephony service a viable business. In fact, IP Telephony service providers in the US and abroad have seen their subscriber base growing at a rapid pace.

The technical challenges in deploying and operating a residential IP Telephony service, however, are not small. One of the main challenges is to make the service transparent to subscribers: The subscribers shall expect to use their existing phones to make or receive calls in the same way as with the existing PSTN service. To enable this level of transparency, the IP Telephony solution has to be tightly integrated. A key element in this end-to-end IP Telephony solution is the provision of an endpoint device that sits at a subscriber's premises that serves as an IP Telephony gateway or telephone adapter. This phone adapter offers one or more standard telephone RJ-11 phone ports – identical to the phone wall jacks at home – where the subscriber can plug in their existing telephone equipment to access phone services. The IP Telephony gateway may connect to the IP network, like the Internet, through an uplink Ethernet connection.

Important!! Please note: The information contained herein is not a warranty from Linksys. Customers planning to use the PHONE ADAPTER in a VoIP service deployment are warned to test all functionality they plan to support in conjunction with the PHONE ADAPTER before putting the PHONE ADAPTER in service. Some information in Section 1 of this guide is written for educational purposes and describes functionality not yet implemented in the PHONE ADAPTER.

1.1. The Session Initiation Protocol

There are many excellent articles and books that discuss the advantages of SIP.¹ Here are some of the more popular details:

- SIP message constructs are very similar to those of HTTP which is well-known to be IP Network (Internet) friendly.
- SIP is transport agnostic – meaning it can be used over TCP/IP or UDP/IP, with or without security.
- SIP has a better chance of traversing NATs than other control protocols.

- SIP enables the implementation of intelligent endpoints to support scalable advanced services.

In a nutshell, SIP is a distributed signaling protocol (as opposed to a centralized protocol such as SS7, MGCP or MEGACO/H.248). With a distributive protocol, the intelligence does not necessarily reside on a central server, but can be built into the individual endpoints. By moving the intelligence to reside within the endpoints at the edge of the network, the processing load of the network application and associated call servers are significantly reduced, thus making the network a very scalable solution.

1.1.1. Components of a SIP Network

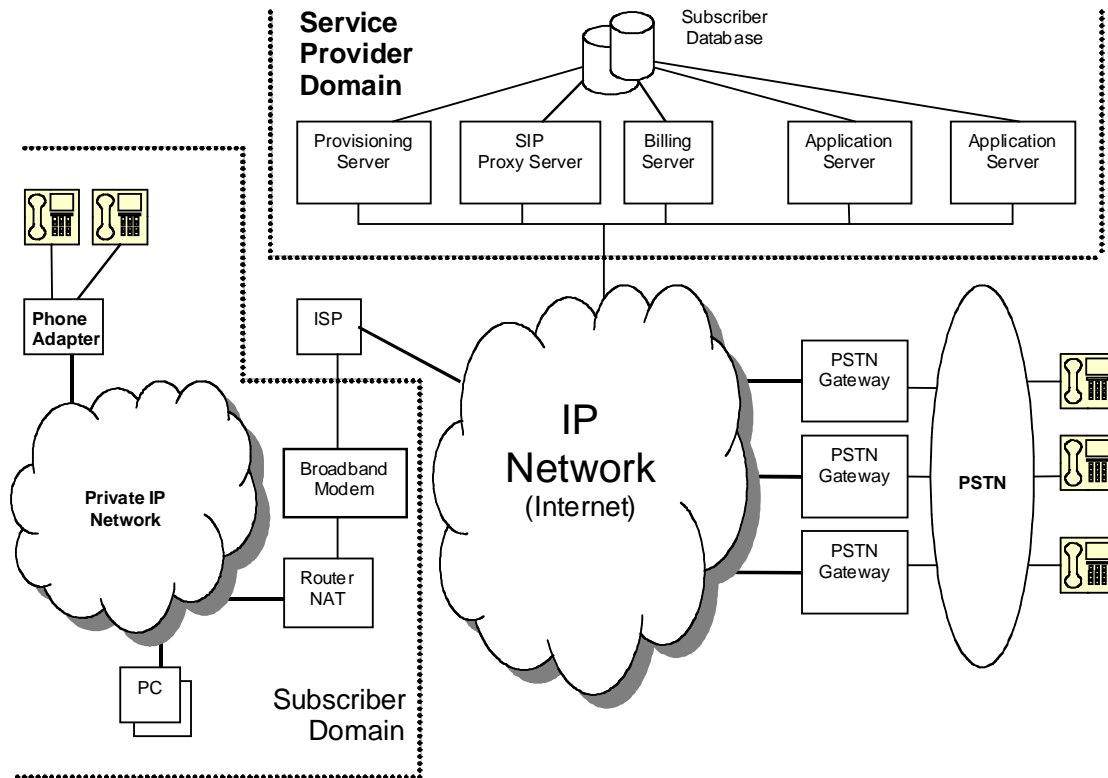

Figure 1 -- Components of a SIP IP Telephony Network

IP Telephony Gateway (PHONE ADAPTER): The PHONE ADAPTER is a small device that sits at the subscriber's premises. It converts between analog telephone signals and IP Telephony signals. It has up to two RJ-11 ports where standard analog telephones can be directly attached, and an RJ-45 interface for the Ethernet connection to the home or business LAN. Intelligence can be built into this device to provide a wide range of features to the subscribers in association with the other elements in the service. The PHONE ADAPTER functions as a SIP User Agent (UA).

Home/SOHO Routers with NAT Functionality: A home/SOHO router is used for routing IP packets between the subscriber's private network and the ISP's public network. If the ISP provides only one public IP address to the subscriber, the devices attached to the private network will be assigned private IP addresses and the router will perform network address translation (NAT) on packets sent from the private network to the public network via the router. Home routers offer the following features:

- An R-J45 WAN interface for connection to the ISP's public network and one or more RJ-45 LAN interfaces for connection to the subscriber's private network. The router directs packets between the private network and the public network.
- A PPPoE client to connect with the ISP through a DSL modem.
- A DHCP client where the router will obtain an IP address, subnet mask, default router assignment, etc., for its WAN interface from a DHCP server on the public network.
- A DHCP server for auto-assignment of private IP addresses, subnet mask, and default router assignment to devices attached to the private network, i.e. computers, IP Telephony

gateways, etc. The default router in this case is the IP address of the LAN interface of the router itself.

- Performs NAT on packets sent from the private network to the public network. This is an important feature such that recipients of the private packets will perceive them as originated from a public IP address (the router's WAN interface) and will therefore return messages to the proper public IP address and port. Different routers may use different rules for allocating port numbers at the WAN interface to forward packets from a private IP address/port to a public IP address/port. The allocated port number is also used for routing packets from external IP addresses to a private address. Most routers will accept a number of static port mapping rules for forwarding packets received on a specific port at the WAN interface to a specific IP address/port in the private network.

PSTN - VoIP Gateways: These devices are required if user agents are expected to make calls to or receive calls from the PSTN. Many gateways may be deployed in order to service a wide area. Gateways also behave like SIP user agents. The proxy server can be configured with cost-saving rules based call routing information so that it may decide which gateway to use depending on the destination and the time of the call. The IP Telephony service provider will assign each subscriber an E164 telephone number so that it may be reached from the PSTN just like any other telephone.

Billing Servers: Billing servers are used to generate billing data per usage of the IP Telephony service. Typically, the service provider will charge a flat fee for unlimited calls between IP Telephony subscribers (on-net-to-on-net calls). Per use or minute chargers will be incurred only when the subscriber makes calls to PSTN numbers (on-net-to-off-net calls) through one of the PSTN gateways. CDR (call detail record) data are generated by the PSTN gateway and sent to the billing servers.

Provisioning Servers: Provisioning servers are used to provision the subscriber user agent devices, e.g. the PHONE ADAPTER. When a subscriber signs up for IP Telephony service, he selects an appropriate service level and enters his personal information including billing information. This information is processed by the provisioning server and stored into the service provider's customer database. The provisioning server generates a device profile based on the subscriber's choice of options. The device profile, which is list of configuration parameters, is downloaded into the PHONE ADAPTER from the provisioning server. The PHONE ADAPTER can be configured to contact the provisioning server periodically to check for any update of the device profile, which may include a firmware upgrade or configuration modification to the PHONE ADAPTER.

Application Servers: Application servers are used to provide value added services, such as call forwarding, outgoing or incoming call blocking

Voice Mail Servers: Specialized servers provide voice mail services to the IP Telephony service subscribers. When the subscriber is busy or the PHONE ADAPTER is out of service for maintenance or other reason, incoming calls to the subscriber may be redirected to the voice mail servers where the caller can leave a voice mail. The voice mail server will then notify the subscriber's PHONE ADAPTER of the availability of voice mail(s) in his mailbox. The subscriber can then contact the voice mail server to retrieve his voice mail(s). The PHONE ADAPTER can indicate the message-waiting status to the subscriber through a number of methods such as stuttered dial tone heard through the telephone every time the subscriber lifts up the handset until the voice mail is retrieved.

1.1.2. Provisioning Overview

The PHONE ADAPTER is configurable in many ways such that it can provide a wide range of customizable services and operate in many diverse environments with a variety different vendors' SIP Proxy Servers, VoIP Gateways, Voice Mail Servers, NAT applications, etc. Provisioning is the process by which the PHONE ADAPTER obtains a set of configuration parameters in order for it to operate in the Service Provider's network.

The complete set of configuration parameters for an PHONE ADAPTER corresponding to an individual subscriber is referred to as a configuration profile or simply a Profile. The Profile can be encoded as an XML file or a simple plain text file with a list of tag/value pairs. When the PHONE

ADAPTER unit is shipped from the factory, it contains a default common Profile and is considered Unprovisioned. To save costs and expedite delivery, however, it is very desirable that an Unprovisioned unit can be shipped directly from the factory to the subscriber's location without any preprocessing by the Service Provider.

The PHONE ADAPTER contacts the Service Provider's provisioning server via the IP network or Internet when it is plugged into the subscriber's home or business Local Area Network (LAN) – assuming the provisioning server is reachable from the subscriber's home network – to pull the designated profile to be installed in that particular PHONE ADAPTER unit. Furthermore, the PHONE ADAPTER unit will periodically contact the provisioning server to download an updated profile. The protocol for downloading the configuration profile can be “clear text” TFTP or HTTP data or it can be encrypted TFTP, HTTP or HTTPS data if security is required. Security will be discussed in more details in a later section.

This type of autonomous remote provisioning, where the individual PHONE ADAPTER unit pulls the profile from the provisioning server is very scalable and flexible. Using this provisioning method, a large number of PHONE ADAPTER units can be provisioned simultaneously and updated periodically.

However, some basic information must be provided to the PHONE ADAPTER before it can be provisioned in this fashion: a) the IP address or domain name of the provisioning server to contact, and b) an ID and/or a password to send to the provisioning server such that it can associate it with a specific subscriber and obtain the corresponding profile. This information can be sent out-of-band to the subscriber via secured email or in a letter inside a welcome kit, for example. The subscriber might need to punch in some numbers using a telephone connected to the PHONE ADAPTER in order to enter this information into the unit. The PHONE ADAPTER provides an easy-to-use interface with audio instructions to make this initial configuration process as painless as possible. An alternative is for the unit to be provisioned with this basic information by the Service Provider before the unit is shipped to the subscriber.

In addition to the batch mode of remote provisioning, the PHONE ADAPTER allows an interactive mode of local provisioning. One way to offer this feature is through the use of an IVR system (accessed through an attached telephone set). The user can access a diagnostic or configuration menu to check the status of the device or to change some of the settings. This method of provisioning may be applied by an administrator when the device is at the Service Provider's office, or by the subscriber under the guidance of trained personnel during over-the-phone troubleshooting.

A third method of entering provisioning information into the PHONE ADAPTER is by way of its integral web server via a browser on a PC. The subscriber has the option to set and adjust configuration parameters via an easy-to-use, password protected graphical user interface. This method of provisioning might be preferred by administrators who wish to access the PHONE ADAPTER over a secure corporate/institutional LAN or by the residential subscriber who is a “power user.”

1.1.3. Security Overview

Security may be applied at many levels in the context of the PHONE ADAPTER. The following are examples of information that should be secured:

- The configuration profile pulled from the provisioning server – The downloading of the profile should be secured since it contains authentication (password/user name ID / number) information for accessing subscriber telephony services. It may also contain other passwords and/or encryption keys used for a variety of management and service operations.
- The administration password to the PHONE ADAPTER unit – The unit must disallow access to administrative functions to unauthorized users. This access can be controlled with an administrator password. The administrator password can be one of the parameters in the PHONE ADAPTER configuration profile.

- The SIP signaling messages – The SIP messages exchanged between the SIP proxy server and the PHONE ADAPTER should be encrypted with a secret key. This can be achieved, for instance, by transporting SIP over TLS.
- RTP packets – The RTP payload exchanged between SIP user agents can be encrypted with a secret key to protect against eavesdropper. The secret key can be negotiated with proper SIP signaling messages. Hence the signaling path must be secured also.

1.1.3.1. Proxy Servers

Proxy servers handle two functions:

1. Accept registrations from the SIP user agents,
2. Proxy requests and responses between user agents.

Registration is the process by which a user agent tells the proxy who it is and at what IP address and port that it can be reached via SIP. Registration usually expires within a finite period (e.g., 60s or 3600s) and the UA shall renew their registration periodically before the last registration expires. When a user agent initiates a call, it sends a SIP INVITE request to the proxy server and indicates the target recipient of the call. The proxy server then consults a database to determine where to forward the request to the destination user agent. The proxy server can request authentication credentials from the user agent before granting the service. The credentials are computed by the user agent based on a pre-provisioned password and a challenge “nonce” dynamically generated by the proxy server per request. This mechanism prevents unauthorized user agents from getting IP Telephony services through the proxy server. SIP proxy servers are operated by the IP Telephony service provider and resides at the service provider’s domain. They may be implemented in many different ways. They can be stateless, stateful, or B2BUA. Stateless proxies do not maintain states of each call; they simply proxy the requests and responses between the user agents. Hence they are the simplest, most scalable, but provide the least types of services. Advanced IP Telephony services are possible with these proxies only with intelligent user agent devices that are capable of delivering these services without proxy intervention. Stateful proxies maintain the call state of each call and can provide more intelligent services at the expense of more processing load per call. B2BUA proxies process every request and response from the user agents and are capable of providing very advance services even with relatively simple user agent devices. Obviously B2BUA proxies have the highest processing load per call.

1.1.4. SIP Services

Today’s PSTN offers a large number of enhanced services in addition to basic phone services. Most of the services offered by the PSTN are accessed by the subscribers through their telephone sets. The subscribers provide their input by talking into the handset, pressing the keypad, the switch hook or flash button, while the PSTN presents instructions/information/confirmation to the subscribers through a variety of audio tones, beeps and/or announcements. The PHONE ADAPTER supports a comparable range of services via a similar user interface in order to make the IP Telephony service transparent to subscribers.

The PHONE ADAPTER is fully programmable and can be custom provisioned to emulate just about any traditional telephony service available today. This ability to transparently deliver legacy services over an IP network coupled with the availability of Internet connected devices (PCs, PDA, etc.) and browsers opens up a new world of potential offerings that a provider can use to differentiate their service and grow their business.

The following is a list of commonly supported phone services:

1.1.4.1. Basic Services

1.1.4.1.1. Making Calls to PSTN and IP Endpoints

This is the most basic service. When the user picks up the handset, the PHONE ADAPTER provides dial tone and is ready to collect dialing information via DTMF digits from a touch tone telephone. While it is possible to support overlapped dialing within the context of SIP, the PHONE ADAPTER collects a complete phone number and sends the full number in a SIP INVITE message to the proxy server for further call processing. In order to minimize dialing delay, the PHONE ADAPTER maintains a dial plan and matches it against the cumulative number entered by the user. The PHONE ADAPTER also detects invalid phone numbers not compatible with the dial plan and alerts the user via a configurable tone (reorder) or announcement.

1.1.4.1.2. Receiving Calls from PSTN and IP Endpoints

The PHONE ADAPTER can receive calls from the PSTN or other IP Telephony subscribers. Each subscriber is assigned an E.164 phone number so that they may be reached from wired or wireless callers on the PSTN. The PHONE ADAPTER supplies ring voltage to the attached telephone set to alert the user of incoming calls.

1.1.4.2. Enhanced Services

Enhanced Services are provided in addition to Basic calling services and accessed by way of a touchtone phone through a series of menus. Since the service enabled by the PHONE ADAPTER are Internet in nature, these enhanced services can be made better by offering users a web browser based interface to control certain aspects of some or all services.

1.1.4.2.1. Caller ID

In between ringing bursts, the PHONE ADAPTER can generate a Caller ID signal to the attached phone when the phone is on-hook.

Calling Line Identification Presentation (CLIP)

Some subscribers will elect to always block their Caller ID information, yet there may be a circumstance where sending Caller ID information for a particular call is desired, i.e. trying to reach a party that does not accept Caller ID blocked calls.

The subscriber activates this service to send his Caller ID when making an outgoing call. To activate the service, the subscriber enters the corresponding * or # code prior to making the call. This service is in effect only for the duration of the current call.

Calling Line Identification Restriction (CLIR) – Caller ID Blocking

The subscriber activates this service to hide his Caller ID when making an outgoing call. To activate the service, the subscriber enters the corresponding * or # code prior to making the call. This service is in effect only for the duration of the current call.

1.1.4.2.2. Call Waiting

The subscriber can accept a call from a 3rd party while engaging in an active call. The PHONE ADAPTER shall alert the subscriber for the 2nd incoming call by playing a call waiting tone.

Disable or Cancel Call Waiting

By setting the corresponding configuration parameter on the PHONE ADAPTER, the PHONE ADAPTER supports disabling of call waiting permanently or on a per call basis.

Call-Waiting with Caller ID

In between call waiting tone bursts, the PHONE ADAPTER can generate a Caller-ID signal to the attached phone when it is off hook.

1.1.4.2.3. Voice Mail

Message Waiting Indication

Service Providers may provide voice mail service to their subscribers. When voice mail is available for a subscriber, a notification message will be sent from the Voice Mail server to the PHONE ADAPTER. The PHONE ADAPTER indicates that a message is waiting by, playing stuttered dial tone (or other configurable tone) when the user picks up the handset.

Checking Voice Mail

The PHONE ADAPTER allows the subscriber to connect to their voice mail box by dialing their personal phone number.

1.1.4.2.4. Call Transfer

Three parties are involved in Call Transfer: The transferor, transferee, and transfer target. There are 2 flavors of call transfer: Attended Transfer (Transfer with consultation) and Unattended Transfer ("Blind" Transfer).

Attendant Transfer

The transferor dials the number of the transfer target, then he hangs up (or enters some * or # code) when the transfer target answers or rings to complete the transfer.

Unattended or "Blind" Transfer

The transferor enters some * or # code and then dials the number of the transfer target to complete the transfer (without waiting for the target to ring or answer).

1.1.4.2.5. Call Hold

Call Hold lets you put a caller on hold for an unlimited period of time. It is especially useful on phones without the hold button. Unlike a hold button, this feature provides access to a dial tone while the call is being held.

1.1.4.2.6. Three-Way Calling

The subscriber can originate a call to a 3rd party while engaging in an active call.

1.1.4.2.7. Three-Way Ad-Hoc Conference Calling

The PHONE ADAPTER can host a 3-way conference and perform 3-way audio mixing (without the need of an external conference bridge device or service).

1.1.4.2.8. Call Return

The PHONE ADAPTER supports a service that allows the PHONE ADAPTER to automatically dial the last caller's number.

1.1.4.2.9. Call Return on Busy

If the last called number is busy, the subscriber can order this service to monitor the called party and to receive a notification from the PHONE ADAPTER (such as special phone ring) when that party becomes available.

1.1.4.2.10. Automatic Call Back

This feature allows the user to place a call to the last number they tried to reach whether the call was answered, unanswered or busy by dialing an activation code.

1.1.4.2.11. Call Forwarding

These services forward all the incoming calls to a static or dynamically configured destination number based on three different settings. These services may be offered by the PHONE ADAPTER or by the SIP proxy server. They can be activated by entering certain * or # code, followed by entering a

telephone number to forward calls to. The PHONE ADAPTER provides audio instructions to prompt the user for a forwarding number and confirms that the requested service has been activated.

Call FWD – Unconditional

All calls are immediately forwarded to the designated forwarding number. The PHONE ADAPTER will not ring or provide call waiting when Call FWD – Unconditional is activated.

Call FWD – Busy

Calls are forwarded to the designated forwarding number if the subscriber's line is busy because of the following; Primary line already in a call, primary and secondary line in a call or conference.

Call FWD - No Answer

Calls are forwarded to the designated forwarding number after a configurable time period elapses while the PHONE ADAPTER is ringing and does not answer.

1.1.4.2.12. Anonymous Call Blocking

By setting the corresponding configuration parameter on the PHONE ADAPTER, the subscriber has the option to block incoming calls that do not reveal the caller's Caller ID.

1.1.4.2.13. Distinctive / Priority Ringing

The PHONE ADAPTER supports a number of ringing and call waiting tone patterns to be played when incoming calls arrive. The choice of alerting pattern to use is carried in the incoming SIP INVITE message inserted by the SIP Proxy Server (or other intermediate application server in the Service Provider's domain).

1.1.4.2.14. Speed Dialing

The PHONE ADAPTER supports speed dialing of up to eight (8) phone numbers or IP addresses. To enter a telephone number speed dial using a touch tone telephone, the user dials a feature code (*74), followed by a number (2-9), then the destination speed dialed target number. When the user wishes to speed dial a target number, they press the corresponding speed dial assigned number followed by the “#” (pound) key.

Users may also enter/review speed dials from User1/User2 web-pages. This interface or similar is required to enter IP address targets.

1.1.4.3. PSTN Interworking

The PHONE ADAPTER is designed to provide a transparent interworking relationship with the PSTN. Service providers can deploy the PHONE ADAPTER in such a way that PSTN endpoints – wired or wireless – communicating with PHONE ADAPTER endpoints do so without modification to their configuration or network settings.

The service provider may choose to deploy a multi-protocol VoIP network, much the same way the PSTN supports multiple signaling schemes today. Most telecommunication providers operate equipment that supports CAS or channel associated signaling, ISDN signaling and SS7 signaling. When VoIP is introduced or used in the telecommunications landscape, it is likely that the service provider will implement a signaling gateway that supports multiple IP Telephony protocols along with legacy PSTN protocols. The signaling gateway is commonly referred to as a Softswitch.

Architecture and functionality can vary greatly amongst the different softswitch vendors. The protocols used will depend on the types of connections that will be set-up across the service provider's network. If the provider is simply providing transport of calls to/from their network to another provider's network, but not originating or terminating calls with the endpoints, SIP will likely be used for softswitch to softswitch communication.

If the service provider is offering origination and/or termination on endpoint equipment then it is very likely that the softswitch chosen for network operations will support multiple PSTN and VoIP signaling protocols.

The table below lists the most commonly accepted, de-facto standards used when implementing a VoIP signaling scheme based on the type of gateway or endpoint equipment being deployed:

VoIP Equipment Type	Typical Port Density	De-Facto Signaling Standards
Trunking Gateways	Greater Than 500 Ports	H.248-Megaco / MGCP / IPDC
Access Gateways	Between five and 500 Ports	SIP / H.323
PBX/KTS Platforms	Between ten and 500 Ports	SIP / H.323 / SCCP
PBX/KTS Telephone Sets	One Port	SIP / MGCP / SCCP
Phone Adapters and IP Centrex Phones	Up to four Ports	SIP / MGCP

The PHONE ADAPTER supports SIP today. It has the capability to communicate with a variety of endpoints and signaling entities via SIP messages.

1.2. Network Address Translation (NAT) Traversal

1.2.1. What is a NAT or NAPT (Network Address Port Translator)?

A NAT allows multiple devices to share the same external IP address to access the resources on the external network. The NAT device is usually available as one of the functions performed by a router that routes packets between an external network and an internal (or private) one. A typical application of a NAT is to allow all the devices in a subscriber's home network to access the Internet through a router with a single public IP address assigned by the ISP. The IP header of the packets sent from the private network to the public network can be substituted by the NAT with the public IP address and a port selected by the router according to some algorithm. In other words, recipient of the packets on the public network will perceive the packets as coming from the external address instead of the private address of the device where the packets are originated.

In most Internet protocols, the source address of a packet is also used by the recipient as the destination to send back a response. If the source address of the packets sent from the private network to the public network is not modified by the router, the recipient may not be able to send back a response to the originator of the message since its private source IP address/port is not usable. When a packet is sent from a device on the private network to some address on the external network, the NAT selects a port at the external interface from which to send the packet to the destination address/port. The private address/port of the device, the external address/port selected by the NAT to send the packet, and the external destination address/port of the packet form a NAT *Mapping*.

The mapping is created when the device first sends a packet from the particular source address/port to the particular destination address/port and is remembered by the NAT for a short period of time. This period varies widely from vendor to vendor; it could be a few seconds, or a few minutes, or more, or less. While the mapping is in effect, packets sent from the same private source address/port to the same public destination address/port is reused by the NAT. The expiration time of a mapping is extended whenever a packet is sent from the corresponding source to the corresponding destination.

More importantly, packets sent from that public address/port to the external address/port of the NAT will be routed back to the private address/port of the mapping session that is in effect. Some NAT devices actually reuse the same mapping for the same private source address/port to any external IP address/port and/or will route packets sent to its external address/port of a mapping from any external

address/port to the corresponding private source address/port. These characteristics of a NAT can be exploited by an PHONE ADAPTER to let external entities send SIP messages and RTP packets to it when it is installed on a private network.

1.2.2. VoIP-NAT Interworking

In the case of SIP, the addresses where messages/data should be sent to an PHONE ADAPTER are embedded in the SIP messages sent by the device. If the PHONE ADAPTER is sitting behind a NAT, the private IP address assigned to it is not usable for communications with the SIP entities outside the private network. The PHONE ADAPTER must substitute the private IP address information with the proper external IP address/port in the mapping chosen by the underlying NAT to communicate with a particular public peer address/port. For this the PHONE ADAPTER needs to perform the following tasks:

- Discover the NAT mappings used to communicate with the peer. This could be done with the help of some external device. For example a server could be deployed on the external network such that the server will respond to a special NAT-Mapping-Discovery request by sending back a message to the source IP address/port of the request, where the message will contain the source IP address/port of the original request. The PHONE ADAPTER can send such a request when it first attempts to communicate with a SIP entity in the public network and stores the mapping discovery results returned by the server.
- Communicate the NAT mapping information to the external SIP entities. If the entity is a SIP Registrar, the information should be carried in the Contact header that overwrites the private address/port information. If the entity is another SIP UA when establishing a call, the information should be carried in the Contact header as well as in the SDP embedded in SIP message bodies. The VIA header in outbound SIP requests might also need to be substituted with the public address if the UAS relies on it to route back responses.
- Extend the discovered NAT mappings by sending keep-alive packets. Since the mapping is only alive for short period, the PHONE ADAPTER continues to send periodic keep-alive packets through the mapping to extend its validity as necessary.

1.3. Voice Quality Overview

Voice Quality perceived by the subscribers of the IP Telephony service should be indistinguishable from that of the PSTN. Voice Quality can be measured with such methods as Perceptual Speech Quality Measurement (PSQM) (1-5 – lower is better) and Mean Opinion Score (MOS) (1-5 – higher is better).

The table below displays speech quality metrics associated with various audio compression algorithms:

Algorithm	Bandwidth	Complexity	MOS Score
G.711	64 kbps	Very Low	4.5
G.726	16, 24, 32, 40 kbps	Low	4.1 (32 kbps)
G.729a	8 kbps	Low - Medium	4
G.729	8 kbps	Medium	4
G.723.1	6.3, 5.3 kbps	High	3.8

Please note: The PHONE ADAPTER supports all the above voice coding algorithms.

Several factors that contribute to Voice Quality are described below.

Audio compression algorithm – Speech signals are sampled, quantized and compressed before they are packetized and transmitted to the other end. For IP Telephony, speech signals are usually sampled at 8000 samples per second with 12-16 bits per sample. The compression algorithm plays a large role in determining the Voice Quality of the reconstructed speech signal at the other end. The PHONE ADAPTER supports the most popular audio compression algorithms for IP Telephony: G.711 a-law and μ -law, G.726, G.729a and G.723.1.

The encoder and decoder pair in a compression algorithm is known as a codec. The compression ratio of a codec is expressed in terms of the bit rate of the compressed speech. The lower the bit rate, the smaller the bandwidth required to transmit the audio packets. Voice Quality is usually lower with lower bit rate, however. But Voice Quality is usually higher as the complexity of the codec gets higher at the same bit rate.

Silence Suppression – The PHONE ADAPTER applies silence suppression so that silence packets are not sent to the other end in order to conserve more transmission bandwidth; instead a noise level measurement can be sent periodically during silence suppressed intervals so that the other end can generate artificial comfort noise that mimics the noise at the other end (using a CNG or comfort noise generator).

Packet Loss – Audio packets are transported by UDP which does not guarantee the delivery of the packets. Packets may be lost or contain errors which can lead to audio sample drop-outs and distortions and lowers the perceived Voice Quality. The PHONE ADAPTER applies an error concealment algorithm to alleviate the effect of packet loss.

Network Jitter – The IP network can induce varying delay of the received packets. The RTP receiver in the PHONE ADAPTER keeps a reserve of samples in order to absorb the network jitter, instead of playing out all the samples as soon as they arrive. This reserve is known as a jitter buffer. The bigger the jitter buffer, the more jitter it can absorb, but this also introduces bigger delay. Therefore the jitter buffer size should be kept to a relatively small size whenever possible. If jitter buffer size is too small, then many late packets may be considered as lost and thus lowers the Voice Quality. The PHONE ADAPTER can dynamically adjust the size of the jitter buffer according to the network conditions that exist during a call.

Echo – Impedance mismatch between the telephone and the IP Telephony gateway phone port can lead to near-end echo. The PHONE ADAPTER has a near end echo canceller with at least 8 ms tail length to compensate for impedance match. The PHONE ADAPTER also implements an echo suppressor with comfort noise generator (CNG) so that any residual echo will not be noticeable.

Hardware Noise – Certain levels of noise can be coupled into the conversational audio signals due to the hardware design. The source can be ambient noise or 60Hz noise from the power adaptor. The PHONE ADAPTER hardware design minimizes noise coupling.

End-to-End Delay – End-to-end delay does not affect Voice Quality directly but is an important factor in determining whether subscribers can interact normally in a conversation taking place over an IP network. Reasonable delay figure should be about 50-100ms. End-to-end delay larger than 300ms is unacceptable to most callers. The PHONE ADAPTER supports end-to-end delays well within acceptable thresholds.

2. Hardware Overview

The PHONE ADAPTER has one of the smallest form factors on the market. It can be installed in minutes as a table-top or wall mount CPE device. Figures Figure 2 and Figure 3 show the front and rear, of the PHONE ADAPTER, respectively. Figures 4 and 5 show the front and rear, of the RT31P2 Broadband Router, respectively.



Figure 2 – PAP2 Front



Figure 3 – PAP2 Back



Figure 3 – RT31P2 Front



Figure 4 – RT31P2 Back

The PAP2 PHONE ADAPTER has the following interfaces for networking, power and visual status indication:

1. Two (2) RJ-11 Type Analog Telephone Jack Interfaces (Figure 3 , above):

These interfaces accept standard RJ-11 telephone connectors. An Analog touchtone telephone or fax machine may be connected to either interface. If the service supports only one incoming line, the analog telephone or fax machine should be connected to port one (1) of the PHONE ADAPTER. Port one (1) is the outermost telephone port on the PHONE ADAPTER and is labeled “Phone 1.”

2. One Ethernet 10baseT RJ-45 Jack Interface (Figure 3, above):

This interface accepts a standard or crossover Ethernet cable with standard RJ-45 connector. For optimum performance, Linksys recommends that a Category 5 cable or greater be used in conjunction with the PHONE ADAPTER.

The Broadband Router RT31P2 has the following interfaces for networking, power and visual status indication:

1. Two (2) RJ-11 Type Analog Telephone Jack Interfaces (Figure 4, above):

These interfaces accept standard RJ-11 telephone connectors. An Analog touchtone telephone or fax machine may be connected to either interface. If the service supports only one incoming line, the analog telephone or fax machine should be connected to port one (1) of the RT31P2. Port one (1) is the outermost telephone port on the RT31P2 and is labeled “Phone 1.”

2. Four (4) Ethernet 10/100 baseT, three (3) for Local Network and one (1) for Internet, all the 4 ports uses RJ-45 Jack Interface, (Figure 5, above):

This interface accepts a standard or crossover Ethernet cable with standard RJ-45 connector. For optimum performance, Linksys recommends that a Category 5 cable or greater be used in conjunction with the PHONE ADAPTER.

3. LEDs

2.1. Phone Adapter LED Status

LED	Color(s)	Activity	Description
Power	Blue	Off	Power OFF
		Blue On	Power On / Device Ready
		Blue Blinking	Booting / System Self-Test / Firmware upgrade
		Red On	POST (Power On Self Test) failure (not bootable) or Device malfunction
Ethernet	Blue	Off	No Connection on Ethernet
		Blue On	Ethernet Connection established
		Blue Blinking	Data Sending / Receiving
Phone 1 / Phone 2	Blue	Off	Phone is not in use/not provisioned or registered
		Blue On	Registered/provisioned
		Blue Blinking	Phone is in use/Incoming Call detected

2.2. Broadband Router (RT31P2) LED Status

LED	Color(s)	Activity	Description
Power	Green	Off	Power OFF
		Solid Green	Power On
		Green Blinking	Booting / System Self-Test / Firmware upgrade
		Red On	POST (Power On Self Test) failure (not bootable) or Device malfunction
Ethernet	Blue	Off	No Connection on Ethernet
		Solid Green	Ethernet Connection established
		Green Blinking	Data Sending / Receiving
Phone 1 / Phone 2	Blue	Off	Phone is not in use/not provisioned or registered
		Green On	Registered/provisioned
		Green Blinking	Phone is in use/Incoming Call detected

4. One 5 Volt Power Adapter Interface (Figure 3, above) for PAP2 Phone Adapter and 12 Volt Power Adapter for the Broadband Router (RT31P2)

This interface accepts the PHONE ADAPTER power adapter that came with the unit. Linksys does not support the use of any other power adapters other than the power adapter that was shipped with the PHONE ADAPTER unit or the Broadband Router (RT31P2)

Please check to make sure that you have the following package contents:

1. Linksys Phone Adapter Unit or Linksys Broadband Router (RT31P2)
2. Ethernet Cable
3. 5 Volt (PAP2) or 12 Volt (RT31P2) Power Adapter
4. CD with User Guide

You will also need:

1. One or Two Analog Touch Tone Telephones (or Fax Machine)
2. Access to an IP Network via an Ethernet Connection
3. One or Two RJ-11 Phone Cable(s).

Please observe the following steps to install the PHONE ADAPTER. From the rear Side of the PHONE ADAPTER:

1. Insert a standard RJ-45 Ethernet cable (included) into the LAN port.2. Insert the power adapter cable into the 5V power adapter cable receptacle. Ensure that the power adapter jack is snugly attached to the PHONE ADAPTER.
2. Insert a standard RJ-11 telephone cable into the Phone 1 port.2. Connect the other end of the cable to an analog telephone or fax machine.
3. Insert a standard RJ-11 telephone cable into the Phone 2 port (Optional)
4. Connect the other end of the cable to an analog telephone or fax machine.

Note: Do not connect RJ-11 telephone cable from the PHONE ADAPTER to the wall jack to prevent any chance of connection to the circuit switched Telco network. You may now insert the plug end of the power adapter into a live power outlet which will power up the PHONE ADAPTER.

3. Software Configuration Mechanisms

The PHONE ADAPTER provides for secure remote provisioning and remote upgrade. Linksys recommends that providers use a secure first-time provisioning mechanism using HTTPS (described in more detail in section 3.2). Subsequent, provisioning is achieved through configuration profiles transferred to the device via TFTP, HTTP or HTTPS. These configuration profiles can be encrypted using AES 256-bit symmetric key encryption using a key configured into the device during the initial HTTPS provisioning stage. As an alternative method for initial configuration, an unprovisioned PHONE ADAPTER can receive an encrypted profile specifically targeted for that device without requiring an explicit key, although this is not as secure as using HTTPS.

The PHONE ADAPTER can be configured to resync its internal configuration state to a remote profile periodically and on power up. An administrator can also remotely trigger a profile resync by sending an authenticated SIP NOTIFY request to the PHONE ADAPTER.

Likewise, remote upgrades are achieved via TFTP, HTTP or HTTPS. The PHONE ADAPTER upgrade logic is capable of automating multi-stage upgrades, in case intermediate upgrades are ever required to reach a future upgrade state from an older release.

General purpose parameters are provided as an additional aid to service providers in managing the provisioning process. The administrator can configure simple comparisons, translations, concatenations, and parameter substitution with the aid of these parameters.

All profile resyncs are attempted only when the PHONE ADAPTER is idle, since they may trigger a software reboot. User intervention is not required to initiate or complete a profile update or firmware upgrade. In general, most configuration changes take effect without requiring a reboot.

The PHONE ADAPTER also provides a Web Interface with two-level access (user-level and admin-level) to configuration parameters. For standalone PHONE ADAPTERS (which contain no router or NAT functionality), an IVR (Interactive Voice Response) interface is also available for configuring basic networking.

3.1. Configuration Profile Formats

The PHONE ADAPTER configuration profile is an XML or binary file with encoded PHONE ADAPTER parameter values and optionally user access permissions for those parameters. By convention, the profile is named with the extension “.cfg” (e.g. pap2.cfg). An administrator can easily generate the XML format and compress and/or encrypt this file with off-the-shelf tools (e.g. gzip, openssl).

The XML configuration file always begins with the top-level element <flat-profile>. Within this element are any number of the configuration elements which are visible in the GUI. The XML tag names are case-sensitive and are identical to the names in the GUI, except that characters other than hyphen, period, underscore, and alphanumeric characters from the GUI are replaced with an underscore in the XML names. For example, User ID(1) becomes <User_ID_1_> .

Empty elements (ex: <element/>) or missing elements do not change the value already stored in memory. An opening and closing tag (ex: <element></element>) with no included value, deletes the value stored in memory. Standard XML comments and arbitrary whitespace can be included in the file for readability purposes. Note that in XML, less-than (“<”) and ampersand (“&”) characters within an element must be escaped (using “<” and “&” respectively). Element names in XML are case-sensitive.

```
<flat-profile>
  <Profile_Rule>https://config.provider.net/linksys/$MA-cfg.xml
</Profile_Rule>
  <Resync_Periodic>86400</Resync_Periodic>
  <Admin_Passwd>9b4cef5677a129</Admin_Passwd>

  <Proxy_1_>sip.provider.net</Proxy_1_>
  <User_ID_1_>1234567890</User_ID_1_>
  <Password_1_>YhJ89_Luk4E</Password_1_>
  <Display_Name_1_>1234567890</Display_Name_1_>
  <Line_Enable_2_>0</Line_Enable_2_>
</flat-profile>
```

The Linksys Supplementary Profile Compiler tool (SPC) is provided for compiling a plain-text file containing parameter-value pairs into a binary cfg file which is optionally encrypted. The spc tool is available from Linksys for the Win32 environment (spc.exe), Linux-i386-elf environment (spc-linux-i386-static) and for the OpenBSD environment.

The syntax of the plain-text file accepted by the profile compiler is a series of parameter-value pairs, with the value in double quotes. Each parameter-value pair is followed by a semicolon, e.g. parameter_name “parameter_value”;. If no quoted value is specified for a parameter (or if a parameter specification is missing entirely from the plain-text file) the value of the parameter will remain unchanged in the PHONE ADAPTER.

The SPC syntax also controls the parameter’s user-level access when using the built-in web interface to the PHONE ADAPTER (PAP2-only). An optional exclamation point or question mark, immediately following the parameter name, indicates the parameter should be user read-write or read-only,

respectively. If neither mark is present, the parameter is made inaccessible to the user from the web interface. Note that this syntax has no effect on the admin-level access to the parameters.

When using the SPC, a service provider is given full control over which parameters become inaccessible, read-only, or read-write following provisioning of the PHONE ADAPTER.

If the parameter specification is missing entirely from the plain-text file, the user-level access to the parameter will remain unchanged in the PHONE ADAPTER. If the plain-text file contains multiple occurrences of the same parameter-value specification, the last such occurrence overrides any earlier ones.

Parameter names in the plain-text file must match the corresponding names appearing in the PHONE ADAPTER web interface, with the following modifications:

- Inter-word spaces are replaced by underscores '_' (e.g. Multi_Word_Parameter).
- For the PHONE ADAPTER, line and user specific parameters use bracketed index syntax to identify which line or user they refer to (e.g. Line_Enable[1] and Line_Enable[2]).

Comments are delimited by a '#' character up to the end-of-line. Blank lines can be used for readability.

```
Parameter_name [ '?' | '!' ] ["quoted_parameter_value_string"] ';' 
```

Example of plain-text file entries:

```
# These parameters are for illustration only

Feature_Enable      ! "Enable" ; # user read-write
Another_Parameter   ? "3600" ; # user read-only
Hidden_Parameter    "abc123" ; # user not-accessible

Some_Entry          ! ; # user read-write, leave value unchanged
```

Multiple plain text files can be spliced together to generate the source for each CFG file. This is accomplished by the "import" directive: the literal string "import" (placed at the start of a new line) followed by one or more spaces and the file name to splice into the stream of parameter-value pairs. The following example illustrates. File splicing can be nested several files deep.

```
# base.txt contains . . .
Param1 "base value 1" ;
Param2 "base value 2" ;
. . .

# Phone Adapter1234.txt contains . . .
import base.txt
Param1 "new value overrides base" ;
Param7 "particular value 7" ;
. . .
```

```
# The Phone Adapter1234.txt file above is equivalent to . . .
Param1 "base value 1" ;
Param2 "base value 2" ;
. . .
Param1 "new value overrides base" ;
Param7 "particular value 7" ;
. . .
```

A sample plain-text file, containing default parameter-value and access settings for the PHONE ADAPTER can be obtained from the profile compiler tool, using the following command-line arguments.

```
spc --sample-profile defaults.txt
```

In both the XML and SPC configuration formats, Boolean parameter values that evaluate to true are any one of the values {Yes | yes | Enable | enable | 1}. Boolean values that evaluate to false are any one of the values {No | no | Disable | disable | 0}.

3.1.1. Using the Supplemental Profile Compiler

Once a plain-text file has been generated with the desired parameter settings, it needs to be compiled into a binary CFG file. The profile compiler can generate a generic unencrypted CFG file, a targeted CFG file (encrypted for a unique PHONE ADAPTER), a generic key encrypted CFG file, or a targeted and key encrypted CFG file.

A generic CFG file (non-targeted) is accepted as valid by any PHONE ADAPTER device. A targeted CFG file is only accepted as valid by the PHONE ADAPTER device bearing the target MAC address. Targeted CFG files are encrypted with a 128-bit algorithmically generated key, and therefore do not require a key to be issued explicitly. Targeted CFG files provide a basic level of security for remotely locking an otherwise unprovisioned PHONE ADAPTER.

The binary configuration format supports RC4 and AES symmetric key algorithms, with keys of up to 256 bits. The key can be specified explicitly as a hex-string, or it can be generated from a password or a quoted pass-phrase. In the case of passwords and pass-phrases, the internally generated key is 128 bits in length.

The following command-line syntax generates a generic and unencrypted CFG file:

```
spc pap2.txt pap2.cfg
```

A targeted CFG file (with basic encryption) is specified by supplying the MAC address of the target device:

```
spc --target 000e08aaa010 pap2.txt pap2.cfg
```

An encrypted CFG file requires either a password (or quoted pass-phrase) or a hex-string. The following lines illustrate command-line invocations for various combinations of keys and algorithms.

```
spc --rc4 --ascii-key apple4sale pap2.txt pap2.cfg
spc --aes --ascii-key lucky777 pap2.txt pap2.cfg
spc --aes --ascii-key "my secret phrase" pap2.txt pap2.cfg
spc --aes --hex-key 8d23fe7...a5c29 pap2.txt pap2.cfg
```

A CFG file can be both targeted and key encrypted, as suggested by the following example:

```
spc --target 000e08aaa010 --aes --hex-key 9a20...eb47 a.txt a.cfg
```

The status messages printed by spc can be suppressed with the "--quiet" command line option. Or they can be redirected to a file, with the "--log file_name" command line option. In the latter case, the spc command line invocation itself is also printed in the log file, preceded by a timestamp.

```
spc --quiet . . .
spc --log prov.log . . .
```

3.1.2. Encrypting and Compressing XML configuration files

The Linksys PHONE ADAPTER supports encrypted XML configuration profiles. This can be used for subsequent configuration files stored on or generated by either TFTP or HTTP servers. When used in concert with HTTPS for initial config, this provides complete security, but only uses the HTTPS server for initial enrollment. For example, an example configuration file in XML setup to download an encrypted XML file via HTTP looks like this:

```
<flat-profile>
  <Profile_Rule>[--key $B] http://config.provider.net/linksys/established/$MA.xml
</Profile_Rule>
  <Resync_Periodic>86400</Resync_Periodic>
  <GPP_B >9b4cef5677a129</GPP_B>
  <Admin_Passwd>9b4cef5677a129</Admin_Passwd>

  <Proxy_1_>sip.provider.net</Proxy_1_>
  <User_ID_1_>1234567890</User_ID_1_>
  <Password_1_>YhJ89_Luk4E</Password_1_>
  <Display_Name_1_>1234567890</Display_Name_1_>
  <Line_Enable_2_>0</Line_Enable_2_>
</flat-profile>
```

An XML configuration file can be encrypted using the openssl command line utility as shown below. (Note that aes encryption is available beginning with OpenSSL versions 0.9.7. OpenSSL is freely available from <http://www.openssl.org>)

```
openssl aes-256-cbc -e -in cleartextconfig -out encryptedconfig -k 9b4cef5677a129
```

This utility generates 8-bytes of salt (which is prepended to the encrypted configuration file), and then calculates an Initialization Vector (IV) and an 256-bit encryption key using the key phrase provided on the command line. The TA recognizes the leading characters "Salted__" as a hint to find the salt and decrypt the configuration file.

Linksys XML configuration files can be compressed using the gzip compression algorithm. Gzip is available from <http://www.gzip.org> .

```
gzip cleartextconfig.xml
```

If both compression and encryption are used, the clear text version must be compressed before it is encrypted. The PHONE ADAPTER does not recognize files which are encrypted and then compressed since encrypted files are uncompressible. The Linksys PHONE ADAPTER automatically detects if a file is compressed or encrypted.

3.2. Secure Initial Configuration

Linksys recommends a secure configuration system to providers to protect them from theft of service, account forgery, and denial of service. To that end, Linksys Terminal Adapters are provisioned at the factory with a public key certificate signed by the Linksys certificate authority.

The first step in this process is for the Linksys terminal adapters to use HTTPS to initially contact the configuration server specified in the Profile_Rule. The initial URL can be configured into the TA at manufacturing time for order over a certain size, it can be added during a staging process, or it can be provided via the web interface as described in the next section. The PHONE ADAPTER opens a TCP connection to the initial configuration server, and sends an SSLv2 ClientHello message. The configuration server then presents a server certificate signed by Linksys in a ServerHello message, and requests the certificate of the client. The Terminal Adapter validates the server certificate and provides its client certificate. From the client certificate, the provider is assured of the authenticity of the MAC address, serial number, and model number of the Linksys device which has connected. The terminal adapter will then use an HTTP GET over this TLS secure channel to fetch its initial configuration.

An Apache web server can be setup to perform all the certificate verification automatically as configuration directives. An example configuration is listed below:

```
<Directory /linksys/secure-setup/>
  SSLVerifyClient require
  SSLVerifyDepth 1
  SSLRequireSSL
  SSLCertificateFile provider-cert-signed-by-linksys.pem
  SSLCertificateKeyFile provider-private-key.pem
  SSLCertificateChainFile linksys-cert.pem
  SSLCACertificateFile linksys-cert.pem
  SSLRequire ( %{SSL_CLIENT_VERIFY} eq "SUCCESS" \
    and %{SSL_CLIENT_I_DN_O} eq "Linksys" \
    and %{SSL_CLIENT_S_DN_O} eq "Linksys" \
    and %{SSL_CLIENT_S_DN_CN} eq %{REQUEST_FILENAME} )
</Directory>
```

Within this directory, the Apache module `mod_ssl` verifies the client certificate, and verifies that the MAC address in the certificate corresponds to the configuration file it is requesting. Either this directory must contain a configuration file, or a CGI application needs to generate the appropriate config file if that MAC address is configured in your system. (The Apache web server is freely available at <http://www.apache.org>).

Once an initial XML configuration file is downloaded from the provider web server, subsequent configuration can be downloaded from the same server. Alternatively, the individual configuration files can be encrypted using AES 256-bit encryption as described previously, using a key that was conveyed in the initial configuration file. These encrypted configuration files then can be downloaded safely using HTTP or TFTP.

Linksys recommends using an encrypted configuration file. In the unlikely event that the private key of a terminal adapter or the Linksys certificate authority is compromised, terminal adapters which have already enrolled with a provider and use an encrypted configuration file would be unaffected by such a compromise.

3.3. Web Interface

The PHONE ADAPTER provides a built-in web server. Configuration and administration can be performed through this convenient web interface.

3.3.1. Web Interface Conventions

The PHONE ADAPTER line uses the following conventions with the web administration capabilities:

- The PHONE ADAPTER web administration supports two privilege levels: Administrator and User. To use the User privilege, simply point a web browser at the IP address of the PHONE ADAPTER; to use the administrator privilege, use this URL for the PAP2: `http://IP_Address_Of_PHONE_ADAPTER/admin/`, and this URL for the RT31P2: `http://IP_Address_Of_PHONE_ADAPTER/Voice_adminPage.htm` . The default IP address for the LAN interface of the RT31P2 is 192.168.15.1. See the next section for more information about administration privileges.
 - The PHONE ADAPTER supports Internet Explorer 5.5 and above and Netscape 7.0 and above.
 - The web configuration pages can be password protected. See 3.3.2 for more information about password protect.
 - The user name of web Administrator is : **admin**
 - The user name of web User is : **user**
 - **Note:** The user names for both administrator and User are fixed and cannot be changed.
 - After making changes to PHONE ADAPTER configuration parameters, pressing "**Submit All Changes**" button will apply all the changes and if necessary, automatically reboot the device. Multiple changes may be made on multiple page tabs of the web interface at the same time. Pressing "**Submit All Changes**" will apply all the modifications.
- Important Note:** switching between page tabs won't apply the changes to PHONE ADAPTER, The only way to apply the changes is to press the "**Submit All Changes**" button.
- If the "**Undo All Changes**" button is clicked, any modifications to profile parameters *on any and all pages* will be reset back to their original values before modification.

NOTE: Pressing the “Undo All Changes” has no effect on the PHONE ADAPTER; it will only reset the values on the web page.

3.3.2. Administration Privileges

The PHONE ADAPTER supports two levels of administration privileges: Administrator and User, both privileges can be password protected. **Important note:** by factory default, there are no passwords assigned for both Administrator and User.

The Administrator has the privilege to modify all the web profile parameters and can also modify the passwords of both Administrator and User. A User only has the privilege to access part of the web profile parameters; the parameter group that User can access is specified by the Administrator, which can only be done through provisioning.

To access the Administrator level privilege, use the URL for your model number as described in the previous section. If the password has been set for Administrator, the browser will prompt for authentication. The username for Administrator is “admin” and cannot be changed.

To access the User level privilege, use URL: http://IP_Address_Of_PHONE_ADAPTER/. If the password has been set for User, the browser will prompt for User authentication. The username for User is “user” and cannot be changed.

When browsing Administrator pages, one can switch to User privileges by click the link “User Login”. (**Note:** if User password was set, the browser will prompt for User authentication when you click “User Login” link). On the other side, from the User pages you can switch to Administrator privilege by clicking the link “Admin Login.” Authentication is needed if Administrator password has been set.

Warning: Switching between the User and Administrator will discard the uncommitted changes that have already been made on the web pages.

3.3.3. Basic and Advanced Views

The PAP2 web configuration interface provides a Basic and an advanced view from which the various configuration parameters can be accessed. The PHONE ADAPTER Provisioning tab is only visible from the Advanced Administrator view of the web interface.

Warning: Switching between the basic and advanced view will discard the uncommitted changes that have already been made on the web pages.

3.4. Functional Configuration URLs

The web interface of the PHONE ADAPTER supports several functions through special URLs: Upgrade, Reboot, Profile Resync, and Factory Reset. Administrator privilege is needed for these functions.

Note that on the RT31P2, these URLs are only accessible from the LAN interface, unless the Admin_Passwd has been set and the Enable_Web_Admin_Access parameter is set.

3.4.1. Upgrade URL

Through upgrade URL you can upgrade the PHONE ADAPTER to a firmware specified by the URL. Note: If the value of “upgrade enable” parameter in Provisioning tab is no, you cannot upgrade the PHONE ADAPTER even if the web page tells you that the upgrade will be done when it is not in use. See 4.2.1 to get more information on firmware upgrade.

The syntax of Upgrade URL is:

[http://<PAP2-ip-addr>/upgrade?\[protocol://\]\[server-name:port\]\[firmware-pathname\]](http://<PAP2-ip-addr>/upgrade?[protocol://][server-name:port][firmware-pathname]) or

[http://<PAP2-ip-addr>/admin/upgrade?\[protocol://\]\[server-name\[:port\]\]\[/firmware-pathname\]](http://<PAP2-ip-addr>/admin/upgrade?[protocol://][server-name[:port]][/firmware-pathname])

If no protocol is specified, TFTP is assumed. Note: Only TFTP is supported in the current release.

If no server-name is specified, the host that requests the URL is used as server-name.

If no port specified, default port of the protocol is used. (69 for TFTP, 80 for http, 443 for HTTPS)

The “firmware-pathname” is typically the file name of the PHONE ADAPTER binary located in the root directory of the TFTP server. If no firmware-pathname is specified, “/Phone Adapter.bin” is assumed.

For example: <http://192.168.2.217/upgrade?ftp://192.168.2.251/PAP2.bin>

3.4.2. Resync URL

Through Resync URL you can force the PHONE ADAPTER to do a resync to a profile specified in the URL.

Note: The PHONE ADAPTER will resync only when it is idle.

The syntax of Resync URL is:

[http://<Phone Adapter-ip-addr>/resync?\[\[protocol://\]\[server-name\[:port\]\]/profile-pathname\]](http://<Phone Adapter-ip-addr>/resync?[[protocol://][server-name[:port]]/profile-pathname])

If no parameter follows “/resync?”, the profile rule setting in provisioning is used. See 4.2 for detailed information about profile rule in provisioning

If no protocol is specified, TFTP protocol is assumed. Note: Only TFTP is supported in the current release.

If no server-name is specified, the host that requests the URL is used as server-name.

If no port specified, default port of the protocol is used – 69 for TFTP, 80 for http, 443 for HTTPS.

The profile-path is the path to the new profile to resync with.

For example: <http://192.168.2.217/upgrade?ftp://192.168.2.251/PAP2.scf>

3.4.3. Reboot URL

Through the Reboot URL, you can reboot the PHONE ADAPTER.

Note: Upon request, the PHONE ADAPTER will reboot only when it is idle.

The Reboot URL is: <http://<Phone Adapter-ip-addr>/admin/reboot>

3.4.4. Factory Reset URL

Through the Reset URL, you can perform a factory reset of the PHONE ADAPTER.

Note: Upon request, the PHONE ADAPTER will reset and then reboot only when it is idle.

The Reset URL is: <http://<Phone Adapter-ip-addr>/admin/reset>

3.5. Configuration via the IVR (PAP2 only)

Administrators and/or users can check (read) and set (write) basic network configuration settings via a touchtone telephone connected to one of the RJ-11 phone ports of the PAP2 model PHONE ADAPTER.

Please Note:

Service Providers offering service using the PHONE ADAPTER may restrict, protect or turn off certain aspects of the unit's IVR and web configuration capabilities.

The Interactive Voice Response (IVR) capabilities of the PHONE ADAPTER are designed to give the administrator and/or user basic read/write capabilities such that the unit can attain basic IP network connectivity and the more advanced browser-based configuration menu may be accessed.

1. The PHONE ADAPTER IVR uses the following conventions: By factory default there is no password and no password authentication is prompted for all the IVR settings. If administrator password is set, password authentication will be prompted for certain IVR settings. See 3.4.2 for detailed information about administrator password.

To input the password using the phone keypad, the following translation convention applies:

- o To input: A, B, C, a, b, c -- press '2'
- o To input: D, E, F, d, e, f -- press '3'
- o To input: G, H, I, g, h, i -- press '4'
- o To input: J, K, L, j, k, l -- press '5'
- o To input: M, N, O, m, n, o -- press '6'
- o To input: P, Q, R, S, p, q, r, s -- press '7'
- o To input: T, U, V, t, u, v -- press '8'
- o To input: W, X, Y, Z, w, x, y, z -- press '9'
- o To input all other characters in the administrator password, press '0'

Note: This translation convention only applies to the password input.

For example: to input password "test#@1234" by phone keypad, you need to press the following sequence of digits: **8378001234**.

2. After entering a value, press the # (pound) key to indicate end of input.

- o To Save value, press '1'
- o To Review the value, press '2'
- o To Re-enter the value, press '3'
- o To Cancel the value entry and return to the main configuration menu, press '*' (star)

Notes:

- o The final '#' key won't be counted into value.
- o Saved settings will take effect when the telephone is hung-up and if necessary, the PHONE ADAPTER will automatically reboot.

3. After one minute of inactivity, the unit times out. The user will need to re-enter the configuration menu from the beginning by pressing * * * *.

4. If, while entering a value (like an IP address) and you decide to exit without entering any changes, you may do so by pressing the * (star) key **twice within a half second** window of time. Otherwise, the entry of the * (star) key will be treated as a dot (decimal point).

Example: To enter IP address, use numbers 0 – 9 on the telephone key pad and use the * (star) key to enter a decimal point.

To enter the following IP address value: 192.168.2.215

A. Use the touchtone key pad to enter: **192*168*2*215#**

B. When prompted, enter **1** to save setting to configuration.

C. Hang-up the phone to cause setting to take effect.

- or -

D. Enter the value of the next setting category to modify . . .

5. Hang-up the phone to cause all settings to take effect.

PHONE ADAPTER Interactive Voice Response (IVR) Menu:

IVR Action	IVR Menu Choice	Parameter(s)	Notes:
Enter IVR Menu	* * * *	None	Ignore SIT or other tones until you hear, "Linksys configuration menu. Please enter option followed by the pound key or hang-up to exit."
Exit IVR Menu	3948	None	
Check DHCP	100	None	IVR will announce if DHCP in enabled or disabled.
Enable/Disable DHCP	101	Enter 1 to enable Enter 0 to disable	Requires Password
Check IP Address	110	None	IVR will announce the current IP address of PHONE ADAPTER.
Set Static IP Address	111	Enter IP address using numbers on the telephone key pad. Use the * (star) key when entering a decimal point.	DHCP must be "Disabled" otherwise you will hear, "Invalid Option," if you try to set this value. Requires Password
Check Network Mask	120	None	IVR will announce the current network mask of

			PHONE ADAPTER.
Set Network Mask	121	Enter value using numbers on the telephone key pad. Use the * (star) key when entering a decimal point.	DHCP must be "Disabled" otherwise you will hear, "Invalid Option," if you try to set this value. Requires Password
Check Static Gateway IP Address	130	None	IVR will announce the current gateway IP address of PHONE ADAPTER.
Set Static Gateway IP Address	131	Enter IP address using numbers on the telephone key pad. Use the * (star) key when entering a decimal point.	DHCP must be "Disabled" otherwise you will hear, "Invalid Option," if you try to set this value. Requires Password
Check MAC Address	140	None	IVR will announce the MAC address of PHONE ADAPTER in hex string format.
Check Firmware Version	150	None	IVR will announce the version of the firmware running on the PHONE ADAPTER.
Check Primary DNS Server Setting	160	None	IVR will announce the current setting in the Primary DNS field.
Set Primary DNS Server	161	Enter IP address using numbers on the telephone key pad. Use the * (star) key when entering a decimal point.	Requires Password
Check PHONE ADAPTER's Web Server Port	170	None	IVR will announce the port that the web server is listening on. (Default is 80)
Enable/Disable Web Server of PHONE ADAPTER	7932	Enter 1 to enable Enter 0 to disable	Requires Password
Manual Reboot of Unit	732668	None	After you hear "Option Successful," hang-up. Unit will reboot automatically.

User Factory Reset of Unit WARNING: ALL "User-Changeable" NON-DEFAULT SETTINGS WILL BE LOST! This might include network and service provider data.	877778	Enter 1 to confirm Enter *(star) to cancel operation	PHONE ADAPTER will prompt for confirmation. After confirming, you will hear "Option Successful." Hang-up. Unit will reboot and all "User Changeable" configuration parameters will be reset to factory default values.
Factory Reset of Unit WARNING: ALL NON-DEFAULT SETTINGS WILL BE LOST! This includes network and service provider data.	73738	Enter 1 to confirm Enter * (star) to cancel operation	PHONE ADAPTER will prompt for confirmation. After confirming, you will hear "Option Successful." Hang-up. Unit will reboot and all configuration parameters will be reset to factory default values.

Note: If the Administrator password is not set or the user is allowed to change it, the items marked with "Requires Password" will not require a password.

4. Configuration Parameters

4.1. Data Types

The data types for the PHONE ADAPTER configuration parameters are described below.

- **Uns<n>** – Unsigned n-bit value, where n = 8, 16, or 32. It can be specified in decimal or hex format such as 12 or 0x18 as long as the value can fit into n bits.
- **Sig<n>** – Signed n-bit value. It can be specified in decimal or hex format. Negative values must be preceded by a "-" sign. A '+' sign before positive value is optional
- **Str<n>** – A generic string with up to n non-reserved characters.
- **Float<n>** – A floating point value with up to n decimal places.
- **Time<n>** – Time duration in seconds, with up to n decimal places. Extra decimal places specified are ignored.
- **PwrLevel** – Power level expressed in dBm with 1 decimal place, such as -13.5 or 1.5 (dBm)
- **Bool:** Boolean value of either "yes" or "no"
- **{a,b,c,...}** – A choice among a, b, c, ...
- **IP** – IP Address in the form of x.x.x.x, where x between 0 and 255. For example 10.1.2.100
- **Port** – TCP/UDP Port number (0-65535). It can be specified in decimal or hex format.
- **UserID** – User ID as appeared in a URL; up to 63 characters
- **FQDN** – Fully Qualified Domain Name, such as "sip.Linksys.com:5060", or "109.12.14.12:12345". It can contain up to 63 characters
- **Phone** – A phone number string, such as 14081234567, *69, *72, 345678, or a generic URL such as [1234@10.10.10.100:5068](tel:1234@10.10.10.100:5068), or jsmith@Linksys.com. It can contain up to 39 characters.
- **ActCode** – Activation code for a supplementary service, such as *69. It can contain up to 7 characters.
- **PhTmpl** – A phone number template. Each template may contain 1 or more patterns separated by a ",". White Phone Adapter at the beginning of each pattern is ignored. "?" and "*" represent

wildcard characters. It can contain up to 39 characters. Examples: "1408*", "1510**", "1408123????", "555?1".

- **RscTmpl** – A template of SIP Response Status Code, such as "404, 5**", "61?", "407, 408, 487, 481". It can contain up to 39 characters.
- **CadScript** – A mini-script that specifies the cadence parameters of a signal. Up to 127 characters. Syntax: S₁[:S₂], where S_i=D_i(on_{i,1}/off_{i,1}[,on_{i,2}/off_{i,2}[,on_{i,3}/off_{i,3}[,on_{i,4}/off_{i,4}[,on_{i,5}/off_{i,5}[,on_{i,6}/off_{i,6}]]]]]) and is known as a *section*, on_{i,j} and off_{i,j} are the on/off duration in seconds of a *segment* and i = 1 or 2, and j = 1 to 6. D_i is the total duration of the section in seconds. All durations can have up to 3 decimal places to provide 1 ms resolution. The wildcard character "*" stands for infinite duration. The segments within a section are played in order and repeated until the total duration is played. Examples:

```

Example 1: Normal Ring

60(2/4)

Number of Cadence Sections = 1
  Cadence Section 1: Section Length = 60 s
    Number of Segments = 1
      Segment 1: On=2s, Off=4s

Total Ring Length = 60s

Example 2: Distinctive Ring (short,short,short,long)

60(.2/.2,.2/.2,.2/.2,1/4)

Number of Cadence Sections = 1
  Cadence Section 1: Section Length = 60s
    Number of Segments = 4
      Segment 1: On=0.2s, Off=0.2s
      Segment 2: On=0.2s, Off=0.2s
      Segment 3: On=0.2s, Off=0.2s
      Segment 4: On=1.0s, Off=4.0s

Total Ring Length = 60s

```

- **FreqScript** – A mini-script that specifies the frequency and level parameters of a tone. Up to 127 characters. Syntax: F₁@L₁[,F₂@L₂[,F₃@L₃[,F₄@L₄[,F₅@L₅[,F₆@L₆]]]]], where F₁–F₆ are frequency in Hz (unsigned integers only) and L₁–L₆ are corresponding levels in dBm (with up to 1 decimal places). White spaces before and after the comma are allowed (but not recommended)

```

Example 1: Call Waiting Tone

440@-10

Number of Frequencies = 1
  Frequency 2 = 440 Hz at -10 dBm

Example 2: Dial Tone

350@-19,440@-19

```

```

Number of Frequencies = 2
Frequency 1 = 350 Hz at -19 dBm
Frequency 2 = 440 Hz at -19 dBm

```

- ToneScript** – A mini-script that specifies the frequency, level and cadence parameters of a call progress tone. May contain up to 127 characters. Syntax: FreqScript;Z₁[:Z₂]. The section Z_i is similar to the S_i section in a CadScript except that each on/off segment is followed by a frequency components parameter: Z_i = D_i(on_{i,1}/off_{i,1}/f_{i,1}[,on_{i,2}/off_{i,2}/f_{i,2} [,on_{i,3}/off_{i,3}/f_{i,3} [,on_{i,4}/off_{i,4}/f_{i,4} [,on_{i,5}/off_{i,5}/f_{i,5} [,on_{i,6}/off_{i,6}/f_{i,6}]]]]]), where f_{i,j} = n₁[+n₂]+n₃[+n₄]+n₅[+n₆]]]] and 1 < n_k < 6 indicates which of the frequency components given in the FreqScript shall be used in that segment; if more than one frequency component is used in a segment, the components are summed together.

Example 1: Dial Tone

```

350@-19,440@-19;10(*0/1+2)

Number of Frequencies = 2
Frequency 1 = 350 Hz at -19 dBm
Frequency 2 = 440 Hz at -19 dBm
Number of Cadence Sections = 1
Cadence Section 1: Section Length = 10 s
Number of Segments = 1
Segment 1: On=forever, with Frequencies 1 and 2

Total Tone Length = 10s

```

Example 2: Stutter Tone

```

350@-19,440@-19;2(.1/.1/1+2);10(*0/1+2)

Number of Frequencies = 2
Frequency 1 = 350 Hz at -19 dBm
Frequency 2 = 440 Hz at -19 dBm
Number of Cadence Sections = 2
Cadence Section 1: Section Length = 2s
Number of Segments = 1
Segment 1: On=0.1s, Off=0.1s with Frequencies 1 and 2
Cadence Section 2: Section Length = 10s
Number of Segments = 1
Segment 1: On=forever, with Frequencies 1 and 2

Total Tone Length = 12s

```

Example 3: SIT Tone

```

985@-16,1428@-16,1777@-16;20(.380/0/1,.380/0/2,.380/0/3,0/4/0)

Number of Frequencies = 3
Frequency 1 = 985 Hz at -16 dBm
Frequency 2 = 1428 Hz at -16 dBm
Frequency 3 = 1777 Hz at -16 dBm
Number of Cadence Sections = 1
Cadence Section 1: Section Length = 20s
Number of Segments = 4
Segment 1: On=0.38s, Off=0s, with Frequency 1

```

```
Segment 2: On=0.38s, Off=0s, with Frequency 2
Segment 3: On=0.38s, Off=0s, with Frequency 3
Segment 4: On=0s, Off=4s, with no frequency components

Total Tone Length = 20s
```

- **ProvisioningRuleSyntax** – Scripting syntax used to define configuration resync and firmware upgrade rules. Refer to the provisioning discussion in the next section for a detailed explanation of the syntax.
- **DialPlanScript** – Scripting syntax used to specify line 1 and line 2 dial plans. Refer to the dial plan section of this document for a detailed explanation of the syntax.

4.1.1. Conventions

- **<Par Name>** represents a configuration parameter name. In a profile, the corresponding tag is formed by replacing the space with an underscore “_”, such as **Par_Name**.
- An empty default value field implies an empty string <”” >.
- The PHONE ADAPTER shall continue to use the last configured values for tags that are not present in a given profile.
- Templates are compared in the order given. The first, **not the closest**, match is selected. The parameter name must match exactly.
- If more than one definition for a parameter is given in a configuration file, the last such definition in the file is the one that will take effect in the PHONE ADAPTER.
- A parameter specification with an empty parameter value forces the parameter back to its default value. To specify an empty string instead, use the empty string “” as the parameter value.

4.2. Provisioning Related Parameters

Provisioning is controlled by the following parameters (firmware upgrades are discussed later in this section).

- Provision_Enable
- Resync_On_Reset
- Resync_Random_Delay
- Resync_Periodic
- Resync_Error_Retry_Delay
- Forced_Resync_Delay
- Resync_From_SIP
- Resync_After_Upgrade_Attempt
- Resync_Trigger_1
- Resync_Trigger_2
- Resync_Fails_On_FNF
- Profile_Rule
- Profile_Rule_B
- Profile_Rule_C
- Profile_Rule_D
- Log_Resync_Request_Msg
- Log_Resync_Success_Msg
- Log_Resync_Failure_Msg

- GPP_A through GPP_P
- GPP_SA through GPP_SD

Provision Enable:

ParName:	Provision_Enable
Default:	Enable

The CFG profile must be requested by the PHONE ADAPTER, and cannot be pushed from a provisioning server (although a service provider can effectively push a profile by triggering the request operation remotely via a SIP NOTIFY). The functionality is controlled by the Provision_Enable parameter. The parameter enables the functionality encompassed by the remaining provisioning parameters.

In addition, Provision_Enable also gates the ability to issue an explicit resync command from the web interface (discussed earlier in the "Function URLs" section of this document).

Resync on Reset:

ParName:	Resync_On_Reset
Default:	Enable

Resync_On_Reset determines whether the PHONE ADAPTER will attempt to resync with the provisioning server on power-up and following explicit reboot requests.

Resync Random Delay:

ParName:	Resync_Random_Delay
Default:	2

Resync_Random_Delay helps to scatter resync requests from multiple devices uniformly over a period of time, whose duration (in seconds) is indicated by this parameter. Hence, if a number of PHONE ADAPTER devices were to power-up at the same time, their resync requests would be distributed over time, lessening the impact on the provisioning servers.

Resync Periodic:

ParName:	Resync_Periodic
Default:	3600

The PHONE ADAPTER attempts to resync with the provisioning server periodically, provided the Resync_Periodic parameter is configured with a non-zero value. The value (in seconds) indicates the interval between resync attempts. Normally, the PHONE ADAPTER will not start the resync while an

active call is in progress. The PHONE ADAPTER will wait up to Forced_Update_Delay seconds for both lines to become idle. If the adapter still is not idle, the adapter will perform a resync anyway.

Resync Error Retry Delay:

ParName:	Resync_Error_Retry_Delay
Default:	3600

If a resync attempt fails, the PHONE ADAPTER will retry with a delay indicated by the Resync_Error_Retry_Delay parameter, specified in seconds. If the value is zero, the PHONE ADAPTER treats resync failures as though they were successful, and simply waits for the next periodic event to resync.

Resync From SIP:

ParName:	Resync_From_SIP
Default:	Enable

Resync_From_SIP gates the ability of a service provider to trigger a profile resync via a SIP NOTIFY message to the PHONE ADAPTER.

If the PHONE ADAPTER receives a SIP NOTIFY request with an Event header field value of "resync", "reboot", or "restart"; the PHONE ADAPTER will attempt to Digest authenticate the notifier using the authentication password used for registrations on that line if the Auth_Resync-Reboot parameter is set. If this parameter is not set or if the NOTIFY request is authenticated, the PHONE ADAPTER triggers a resync, cold-boot, or warm-boot respectively. The actual resync, reboot, or restart will not take place until the PHONE ADAPTER is idle (i.e. no calls are in progress).

Profile Rule:

ParName:	Profile_Rule
Default:	/spa\$PSN.cfg

ParName:	Profile_Rule_B through Profile_Rule_D
Default:	Empty

The Profile_Rule parameter is a script that identifies the provisioning server to contact when performing a profile resync. The Profile_Rule_B, Profile_Rule_C, and Profile_Rule_D parameters are also scripts used to contact other provisioning URLs. Each profile rule is executed only if the previous profile rule was executed successfully(*).

These strings each supports one level of macro expansion, using a small set of variables. Following macro substitution, the rule is evaluated to obtain the URL of the CFG file to be requested from the provisioning server.

The URL can be partially specified, in which case default values are assumed for the unspecified terms. The filepath portion of the URL must always be specified.

The Profile_Rule supports additional syntax that allows the URL to include conditions, for example based on a function of the firmware release currently running in the PHONE ADAPTER. This mechanism can aid the service provider's firmware upgrade sequence, by allowing them to define different configuration profiles for different stages of an upgrade sequence.

The conditional syntax consists of a sequence of condition-url pairs, separated by the '|' character. The condition component tests the current firmware version number against a specified value. If the last url in the sequence does not have an associated condition, it will be attempted unconditionally.

The sequence of conditions is evaluated until one is satisfied. The URL associated with that condition is then used to resync the PHONE ADAPTER. No additional URLs in the rule are considered.

(*) A profile rule which attempts to fetch a URL succeeds if the profile is received and parsed correctly. If the Resync_Fails_On_FNF parameter is set to No, a profile rule will also succeed if an attempted fetch for a URL returns a File Not Found error message. A profile rule with only assignments always succeeds.

Optional qualifiers can be specified in brackets, preceding each URL.

To ease testing and development, the script syntax also supports using '#' as a comment delimiter (until end-of-parameter). This allows a potentially long script to be temporarily "commented out".

The syntax for the rule is as follows (with standard conventions for URLs):

```
rule = term *( "|" term )
term = [condition] [assignments] [options] url

condition = "(" conditionseq ")" "?"
conditionseq = condelem *( conjunction condelem )
condelem = numcond / vercond / strcond

numcond = number relop number
vercond = [ version ] relop version
relop = "<" / "<=" / ">" / ">=" / "==" / "!="
        / "!" / "gt" / "ge" / "lt" / "le" / "eq" / "ne"
version = major "." minor "." build [ "(" features ")" ]
strcond = cond *( conjunction cond )
strcond = qstr eqop qstr
conjunction = "and"
qstr = DQUOT val DQUOT
eqop = "==" / "!=" / "!" / "eq" / "ne"

assignments = "(" *assignment ")" "!"
assignment(*) = attribute "=" expr ";"
```

```

expr = DQUOTE val DQUOTE

options = "[" *option "]"
option = key-opt / alias-opt / post-opt
key-opt = "--key" key-string
key-string = password / quoted-pass-phrase / hex-string
alias-opt = "--alias" val
post-opt = "--post" val

url = [ method "://" [ server [":" port]]] "/" *(dir "/") file
method = "tftp" / "http" / "https"
server(**) = ip4quad / fqdn

```

(*) Attribute can contain the name of any configuration parameter
(**) If the server and scheme are unspecified, the TFTP server name provided by the LAN's DHCP server is used instead. Also, an FQDN with multiple DNS entries is multiply resolved by the PHONE ADAPTER.

The variables available for macro substitution (with example values) are as follows:

PN	PAP2	Product Name
PSN	PAP2	Product Series Number
MA	000f66aaa010	MAC Address
MAU	000F66AAA010	MAC Address (upper case)
MAC	00:0f:66:aa:a0:10	MAC Addr with Colon separators
SN	CH500D600862	Serial Number
SWVER	1.0.2	Firmware Version Number
HWVER	1.0.1	Hardware Version Number
UPGCOND	1.0.2<1.1	Upgrade(*) Condition
SCHEME	tftp	Access Scheme
SERV	http.example.com	Server Name
SERVIP	10.2.3.200	Server IP Address
PORT	69	TCP/IP Request Port
PATH	/guest/pap2.cfg	File path
IP	192.168.1.102	IP address of the PHONE ADAPTER
EXTIP	45.73.21.44	Configured or discovered external IP address (for example using STUN)
PRVST	0	Error Code of Last Profile Rule(**)
UPGST	0	Error Code of Last Upgrade Rule(**)
ERR	corrupt file	Error/Info(***) message
A to P	some-value	Contents of GPP_A to GPP_P
SA to SD	some-value	Contents of GPP_SA to GPP_SD

(*) Note that the UPGCOND term is particularly useful in the Upgrade_Rule (discussed later in this document), but applies equally as a resync condition. It shows which term of the rule triggered the operation.

(**) See section 6.5 for the values of these macro variables.

(***) Upon successful firmware upgrade, the ERR variable carries the version of the newly installed load.

In addition, the contents of the general purpose parameters, GPP_A, through GPP_P, are available as macro variables A through P, respectively.

A secondary set of general purpose parameters is also available for macro substitution, GPP_SA, GPP_SB, GPP_SC, GPP_SD, using the respective expressions SA, SB, SC, and SD. These parameters are not accessible through the web interface, and can only be set via a configuration profile.

Strings identified above as "val" values are strings which can include variable substitution. The macro variables are invoked by prefixing the name with a '\$' character (e.g. \$MAC). The substitution works even within a quoted string, without requiring additional escapes. If the variable name is immediately followed by an alphanumeric character, enclose the variable name in parentheses (e.g. "\$(MAC)config.xml").

To include a dollar sign in the rule, escape it with another dollar sign. That is \$\$ maps to \$.

Profile_Rule syntax examples (each line is a separate example):

```
/pap2.cfg
pserv.myvoice.com:42000/sip/$MA/pap2.cfg
[--key 6e4f2a8733ba7c90aa13250bde4f6927]ur.well.com/Gj2fLx3Nqbg/a.cfg
(<1.0)?/pre-rel.cfg | /curr.cfg
```

Profile Example Scenarios:

Enterprise LAN with DHCP Supplied TFTP Server Name:

The DHCP server automatically advertises a TFTP server name to service the local network. Each PHONE ADAPTER in the network is supplied a unique CFG file based on its MAC address. The TFTP server would also contain a generic Phone Adapter2000.cfg in its tftp-root directory that contains the Profile_Rule indicated below. It would additionally carry individualized CFG files, one per device, within a tree below the tftp-root node. Each of these files would then individualize the devices.

```
/profiles/$MA/pap2.cfg
```

When first powered-on, unprovisioned devices would download the /pap2.cfg file from the TFTP server indicated by DHCP, (following their manufacturing default setting for the Profile_Rule parameter). The downloaded file would then direct the PHONE ADAPTER to resync to the server and fetch the individualized CFG file, as per the rule above, which completes the provisioning sequence.

VoIP Service Provider:

Conceptually, a service provider solution would follow the steps as in the above example. In addition, it would then proceed to enable stronger encryption by implementing one more provisioning step, with one more level of redirection, involving a random CFG file path and encryption key. Hence, each of the "first-stage" CFG files above would point to a "second-stage" CFG file, with entries such as the following:

```
Profile_Rule "[--key $B] ps.global.com/profiles/active/$A/pap2.cfg" ;
GPP_A "Dz3P2q9sVgx7LmWbvU" ;
GPP_B
"83c1e792bc6a824c0d18f429bea52d8483f2a24b32d75bc965d05e38c163d5ef" ;
```

In practice, the first provisioning stage (which individualizes each PHONE ADAPTER into fetching a unique CFG file) could be preconfigured during manufacturing.

For added security, the second stage, which introduces strong encryption, may be performed in-house, prior to shipping an PHONE ADAPTER to each end-user.

Release 2.0 supports SSL-based key exchanges, alleviating the need for this in-house step, while preserving strong security for the provisioning process.

A provisioning flow chart, from the point of view of the PHONE ADAPTER endpoint is presented in a later section.

Log Resync Request Message:

```
ParName:      Log_Resync_Request_Msg
Default:      $PN $MAC -- Requesting resync $SCHEME://$SERVIP:$PORT$PATH
```

The Log_Resync_Request_Msg is a script that defines the message sent to the configured Syslog server whenever the PHONE ADAPTER attempts to resync with the provisioning server. The string supports one level of macro substitution, with the same variables as for the Profile_Rule above. An empty string does not generate a syslog message.

Log Resync Success Message:

```
ParName:      Log_Resync_Success_Msg
Default:      $PN $MAC -- Successful resync $SCHEME://$SERVIP:$PORT$PATH
```

The Log_Resync_Success_Msg is a script that defines the message sent to the configured Syslog server whenever the PHONE ADAPTER successfully completes a resync with the provisioning server. The string supports one level of macro substitution, with the same variables as for the Profile_Rule above. An empty string does not generate a syslog message.

Log Resync Failure Message:

```
ParName:      Log_Resync_Failure_Msg
Default:      $PN $MAC -- Resync failed: $ERR
```

The Log_Resync_Failure_Msg is a script that defines the message sent to the configured Syslog server whenever the PHONE ADAPTER fails to complete a resync with the provisioning server. The

string supports one level of macro substitution, with the same variables as for the Profile_Rule above. An empty string does not generate a syslog message.

General Purpose Parameters:

ParName:	GPP_A through GPP_P
Default:	empty

GPP_A through GPP_P are the 16 General Purpose Parameters, usable by both the provisioning and the upgrade logic. Each general purpose parameter can be configured to hold any string value. Such a value can then be incorporated in other scripted parameters.

General Purpose Secure Parameters:

ParName:	GPP_SA through GPP_SD
Default:	empty

GPP_SA through GPP_SD are the 4 Secure General Purpose Parameters, usable by both the provisioning and the upgrade logic. Each secure parameter can be configured to hold any string value. Such a value can then be incorporated in other scripted parameters. The secure parameters are not accessible through the PHONE ADAPTER web interface, and can only be set via a configuration profile. Also, the parameters cannot be incorporated as part of a syslog message.

Parameter Name	Description	Type	Default
Provision Enable	Master enable for configuration profile resync operations	Bool	yes
Resync On Reset	Resyncs configuration profile from configuration server whenever the PHONE ADAPTER resets.	Bool	yes
Resync Random Delay	Spread interval for resync requests	Time0	2
Resync Periodic	Resyncs configuration profile periodically after reset.	Time0	3600
Resync Error Retry Delay	Retry interval following resync failure	Time0	3600
Resync From SIP	Enables resync of configuration profile from a SIP command.	Bool	Yes
Resync After Upgrade Attempt		Bool	Yes
Resync Trigger 1			
Resync Trigger 2			
Profile Rule	Configuration profile URL script.	ProfileScript	/Phone Adapter.cfg
Profile Rule B		ProfileScript	
Profile Rule C		ProfileScript	
Profile Rule D		ProfileScript	

Log Resync Request Msg	Syslog message generated when attempting a resync	ProfileMsg	See provisioning discussion section
Log Resync Success Msg	Syslog message generated after a successful resync	ProfileMsg	See provisioning discussion section
Log Resync Failure Msg	Syslog message generated after a failed resync	ProfileMsg	See provisioning discussion section
GPP A thru GPP P	General purpose parameter	String	empty
GPP SA thru GPP SD	General purpose parameter	String	empty

Note: In a customized PHONE ADAPTER, the profile rule would point to a service provider's server.

4.2.1. Firmware Upgrade

The PHONE ADAPTER is firmware upgradeable via TFTP and HTTP. Firmware loads are released as single binary files, which contain all the modules pertaining to any one release version. By convention, the firmware loads are named with the extension ".bin" (e.g. pap2.bin)

The PHONE ADAPTER can be configured to upgrade to a specific version, possibly staging through intermediate releases, if necessary. This process can be automated for a pool of devices through configuration profile parameters.

Alternatively, an individual PHONE ADAPTER can be directed to perform an upgrade to a specific firmware load via its built-in web server interface (this mechanism is discussed in section 3.4.1 of this document).

Firmware upgrades are attempted only when the PHONE ADAPTER is idle, since they trigger a software reboot.

Firmware upgrades are controlled by the following parameters (which operate in a manner similar to but independent of the provisioning parameters).

- Upgrade_Enable
- Upgrade_Error_Retry_Delay
- Upgrade_Rule
- Downgrade_Rev_Limit
- Log_Upgrade_Request_Msg
- Log_Upgrade_Success_Msg
- Log_Upgrade_Failure_Msg

Upgrade Enable:

ParName:	Upgrade_Enable
Default:	Enable

The firmware file must be requested by the PHONE ADAPTER and cannot be pushed from an upgrade server (although a service provider can effectively push a new firmware load by triggering the request operation remotely via the CFG file). The functionality is controlled by the Upgrade_Enable parameter. The parameter enables the functionality encompassed by the remaining upgrade parameters.

In addition, Upgrade_Enable also gates the ability to issue an explicit upgrade command from the web interface (discussed in section 3.4.1 of this document).

Upgrade Error Retry Delay:

ParName:	Upgrade_Error_Retry_Delay
Default:	3600

If an upgrade attempt fails, the PHONE ADAPTER will retry with a delay indicated by the Upgrade_Error_Retry_Delay parameter, specified in seconds. If the value is zero, the PHONE ADAPTER treats upgrade failures as though they were successful, and will not retry to upgrade unless some event triggers a reboot.

Upgrade Rule:

ParName:	Upgrade_Rule and Upgrade_Rule_B
Default:	Empty

The Upgrade_Rule and Upgrade_Rule_B parameters are scripts that identifies the upgrade server to contact during a firmware upgrade. Upgrade_Rule_B is only executed if Upgrade_Rule executed successfully. These strings support one level of macro expansion, using a small set of variables. Following macro substitution, the rule is evaluated to obtain a URL of the firmware file to request from an upgrade server.

The URL can be partially specified, in which case default values are assumed for the unspecified terms. The filepath portion of the URL must be specified.

The Upgrade_Rule supports additional syntax that allows the URL to be a function of the firmware release currently running in the PHONE ADAPTER. This mechanism can aid service providers sequence through a firmware upgrade, by allowing them to automatically stage the upgrade sequence, if so required by the firmware. Also, the Downgrade_Rev_Limit parameter can contain a version string below which the PHONE ADAPTER will not downgrade.

The conditional syntax consists of a sequence of condition-url pairs, separated by the '|' character. The condition component tests the current firmware version number against a specified value.

The sequence of conditions is evaluated until one is satisfied. The URL associated with that condition is then used to upgrade the PHONE ADAPTER. No additional URLs in the rule are considered.

The upgrade will fail if the new firmware load does not satisfy the upgrade rule condition that suggested the URL. This alleviates the possibility of infinite upgrade loops, in case the device has been misconfigured.

The rule syntax is the same as for the Profile_Rule described in a previous section, except that there are no supported optional qualifiers for upgrades at this time. (That is, the bracketed options preceding the URL are not supported in the Upgrade_Rule).

Upgrade Rule Syntax Examples (each line is a separate example):

```
(! 1.0.2)? /Phone Adapter2000/1-00-02/Phone Adapter.bin  
(<1.0)? tftp://pserv.myvoice.com:42001/upg/Phone  
Adapter2000/1.0.2/Phone Adapter.bin  
(<0.99.52)?/Phone Adapter09952.bin | (<1.0.2)?/Phone Adapter10002.bin
```

Log Upgrade Request Message:

```
ParName:      Log_Upgrade_Request_Msg  
Default:      $PN $MAC -- Requesting upgrade  
              $SCHEME://$SERVIP:$PORT$PATH
```

The Log_Upgrade_Request_Msg is a script that defines the message sent to the configured Syslog server whenever the PHONE ADAPTER attempts an upgrade from the upgrade server. The string supports one level of macro substitution, with the same variables as for the Upgrade_Rule above. An empty string does not generate a syslog message.

Log Upgrade Success Message:

```
ParName:      Log_Upgrade_Success_Msg  
Default:      $PN $MAC -- Successful upgrade  
              $SCHEME://$SERVIP:$PORT$PATH -- $ERR
```

The Log_Upgrade_Success_Msg is a script that defines the message sent to the configured Syslog server whenever the PHONE ADAPTER successfully completes an upgrade from the upgrade server. The string supports one level of macro substitution, with the same variables as for the Upgrade_Rule above. An empty string does not generate a syslog message.

Log Upgrade Failure Message:

```
ParName:      Log_Upgrade_Failure_Msg  
Default:      $PN $MAC -- Upgrade failed: $ERR
```

The Log_Upgrade_Failure_Msg is a script that defines the message sent to the configured Syslog server whenever the PHONE ADAPTER fails to complete an upgrade from the upgrade server. The

string supports one level of macro substitution, with the same variables as for the Upgrade_Rule above. An empty string does not generate a syslog message.

Parameter Name	Description	Type	Default
Upgrade Enable	Master enable for firmware upgrade operations	Bool	Yes
Upgrade Error Retry Delay	Retry interval following upgrade failure	Time0	3600
Upgrade Rule	Upgrade script.	UpgradeScript	empty
Log Upgrade Request Msg	Syslog message generated when attempting an upgrade	UpgradeMsg	See provisioning discussion section
Log Upgrade Success Msg	Syslog message generated after a successful upgrade	UpgradeMsg	See provisioning discussion section
Log Upgrade Failure Msg	Syslog message generated after a failed upgrade	UpgradeMsg	See provisioning discussion section

Note: In a customized PHONE ADAPTER, the upgrade rule would point to a service provider's server.

4.2.2. Provisioning Server Redundancy

The Provisioning Server (PS) may be specified as an IP address or a FQDN. PS redundancy is not available in the former case. For the latter, PHONE ADAPTER shall attempt to resolve the IP address of the PS via DNS SRV, then DNS A Record. In either case, the DNS server may return a number of IP addresses with priority (priority can be indicated in the case of SRV record; for A records, all IP addresses have the same priority). The PHONE ADAPTER then contacts the IP address with the highest priority. If that fails, the PHONE ADAPTER shall contact the next available IP address. The PHONE ADAPTER shall continue the process until one of the PS responds. If all PS fail to respond, the PHONE ADAPTER shall log an error to the Syslog server.

4.2.3. Configuring the Web Server and IVR

System Configuration

Parameter Name	Description	Type	Default
Restricted Access Domains	This feature is used when implementing software customization.	Str127	
Enable Web Server	Enable/disable web server of PHONE ADAPTER This feature should only be used on firmware version 1.0.9 or later.	Bool	Yes
Web Server Port	TCP port through which the PHONE ADAPTER web server will communicate	Uns8	80
Enable Web Admin Access	Enable/disable Admin pages of web server of PHONE ADAPTER	Bool	Yes

Protect IVR Factory Reset		Bool	No
Admin Password	The password for administrator	Str63	
User Password	The password for User	Str63	

4.3. Basic Networking Configuration

Configuration parameters in this list are used for setting up basic network connectivity. In general, many of these parameters are set automatically (for example, using DHCP) or are configured by the end user of the device.

Note that the RT31P2 ignores the following parameters: DHCP, Static_IP, NetMask, and Gateway. Other than the DNS_Server_Order and DNS_Query_Mode, the rest these parameters also can be configured from the RT31P2 User GUI.

Network Configuration

Parameter Name	Description	Type	Default
DHCP	Enable/Disable DHCP	Bool	Yes
Host Name	Host Name of PHONE ADAPTER	Str31	
Domain	The network domain of PHONE ADAPTER	Str127	
Static IP	Static IP address of PHONE ADAPTER, which will take effect if DHCP is disabled	IP	0.0.0.0
NetMask	The NetMask used by PHONE ADAPTER when DHCP is disabled	IP	255.255.255.0
Gateway	The default gateway used by PHONE ADAPTER when DHCP is disabled	IP	0.0.0.0
Primary DNS	DNS server used by PHONE ADAPTER in addition to DHCP supplied DNS servers if DHCP is enabled; when DHCP is disabled, this will be the primary DNS server.	IP	0.0.0.0
Secondary DNS	DNS server used by PHONE ADAPTER in addition to DHCP supplied DNS servers if DHCP is enabled; when DHCP is disabled, this will be the secondary DNS server.	IP	0.0.0.0
DNS Query Mode	Do parallel or sequential DNS Query	Choice	Parallel
Syslog Server	Specify the Syslog server name and port. This feature specifies the server for logging PHONE ADAPTER system information and critical events.	FQDN	
Debug Server	The debug server name and port. This feature specifies the server for logging PHONE ADAPTER debug information. The level of detailed output depends on the debug level parameter setting.	FQDN	
Debug Level	The higher the debug level, the more debug information will be generated. Zero (0) means no debug information will be generated.	Choice	0
Primary NTP Server	IP address or name of primary NTP server.	Str127 or IP	
Secondary NTP Server	IP address or name of secondary NTP server	Str127 or IP	

Notes:

- Parallel DNS query mode: PHONE ADAPTER will send the same request to all the DNS servers at the same time when doing a DNS lookup, the first incoming reply will be accepted by PHONE ADAPTER.
- To log SIP messages, Debug Level must be set to at least 2.
- If both Debug Server and Syslog Server are specified, _Syslog messages are also logged to the Debug Server.

4.4. Basic Account Configuration

Basic SIP Account Configuration is typically straightforward, involving only a handful of key parameters. All of these parameters are configured on a per-line basis.

The Line_Enable parameters control whether a line is enabled or not. The Proxy setting is the address of the SIP Registrar (usually collocated with a SIP Proxy) for the account. The User_ID is the username or phone number of the SIP account. The Proxy and User_ID together form the SIP URI. For example: User_ID = alice ; Proxy = sip.provider.net:5060 ; the SIP URI used for registration would be sip:alice@sip.provider.net:5060.

The Password is the password used for Digest authentication. With some providers, the username used for authentication is different from the User_ID used in the SIP From header. For example, Alice Smith could have a User_ID of 1234, and a Digest username of alice.smith. In this situation, set the Auth_ID to alice.smith and set Use_Auth_ID to yes. The Display_Name is the string that will appear in quotes in the From header. It can be an arbitrary string such as a name (for example "Alice Smith") or a local phone number (for example "5551212").

<i>Proxy and Registration</i>			
Proxy	SIP Proxy Server for all outbound requests	FQDN	
Register	Enable periodic registration with the <Proxy>. This parameter is ignored if <Proxy> is not specified.	Bool	Yes
Make Call Without Reg	Allow making outbound calls without successful (dynamic) registration by the unit. If "No", dial tone will not play unless registration is successful	Bool	No
Ans Call Without Reg	Allow answering inbound calls without successful (dynamic) registration by the unit	Bool	No
Register Expires ¹	Expires value in sec in a REGISTER request. PHONE ADAPTER will periodically renew registration shortly before the current registration expired. This parameter is ignored if <Register> is "no". Range: 0 – (2 ³¹ – 1) sec	Time0	3600
Use DNS SRV	Whether to use DNS SRV lookup for Proxy and Outbound Proxy	Bool	No
DNS SRV Auto Prefix	If enabled, the PHONE ADAPTER will automatically prepend the Proxy or Outbound Proxy name with _sip._udp when performing a DNS SRV lookup on that name	Bool	No
Proxy Fallback Intvl	This parameter sets the delay (sec) after which the PHONE ADAPTER will retry from the highest priority proxy (or outbound proxy) servers after it has failed over to a lower priority server. This	Time0	3600

	parameter is useful only if the primary and backup proxy server list is provided to the PHONE ADAPTER via DNS SRV record lookup on the server name. (Using multiple DNS A record per server name does not allow the notion of priority and so all hosts will be considered at the same priority and the PHONE ADAPTER will not attempt to fall back after a fail over)		
Subscriber Information			
Display Name	Subscriber's display name to appear in caller-id	Str23	
User ID	Subscriber's user-id. Usually a E.164 number	Str47	
Password	Subscriber's a/c password	Str23	
Auth ID	Subscriber's authentication ID	Str39	
Use Auth ID	If set to "yes", the pair <Auth ID> and <Password> are used for SIP authentication. Else the pair <User ID> and <Password> are used.	Bool	No

4.5. Configuration for NAT Traversal

In general, there are 3 general approaches to enable NAT traversal available on the PHONE ADAPTER: STUN (Simple Traversal of UDP through NAT), Using an outbound rewriting "proxy", and manual configuration. If the PHONE ADAPTER is not "behind" a NAT, the default settings should be used.

Note: The Linksys model RT31P2 includes NAT (Network Address Translator) functionality. As long as the IP address of the "WAN Port" is a public IP address, the RT31P2 can be configured with all NAT Traversal features (NAT Traversal off), since the PHONE ADAPTER portion shares the same IP address as the WAN Port. If the address obtained on the WAN Port is already a private address, then the RT31P2 still needs to be configured for NAT traversal.

The Outbound Proxy approach works through more than 99% of NATs, but it requires the service provider to relay RTP media packets for every call. To use this approach, set the following parameters: Outbound_Proxy, Use_Outbound_Proxy, NAT_Keep_Alive_Dest, NAT_Keep_Alive_Msg, NAT_Keep_Alive_Intvl, and NAT_Keep_Alive_Enable. If the NAT_Keep_Alive_Msg parameter is set to blank, the PHONE ADAPTER will send a Carriage-Return/Line-Feed as the Keep-Alive Message.

The STUN approach works through more than 95% of home NATs when there is only a single PHONE ADAPTER in use behind the same NAT. The STUN approach requires a STUN server setup by the provider, but uses very few resources. The actual media flows directly between the PHONE ADAPTER and its peer. To configure STUN set the following parameters: STUN_Enable, STUN_Test_Enable, STUN_Server, NAT_Mapping_Enable, Substitute_VIA_Addr, NAT_Keep_Alive_Dest, NAT_Keep_Alive_Msg, NAT_Keep_Alive_Intvl, and NAT_Keep_Alive_Enable.

The Manual Configuration approach requires coordinated administration of the NAT and the PHONE ADAPTER. It is not practical for general retail use, but can be used behind symmetric NATs occasionally found in larger businesses, for troubleshooting, and in circumstances where other mechanisms have been exhausted. To configure the PHONE ADAPTER for manual NAT traversal, set the EXT_IP parameter to the public/translated/outside/external IP address, the EXT_SIP_Port parameters (per line) to the translated port number for this line and PHONE ADAPTER, and the EXT_RTP_Port_Min parameter to the first translated port number reserved for this PHONE

ADAPTER. Also, set the Substitute_VIA_Addr and NAT_Mapping_Enable parameters. Follow the instructions of the NAT software to configure static NAT mappings between the external address and ports (EXT_SIP_Port, EXT_RTP_Port_Min) and the internal address and ports (SIP_Port, RTP_Port_Min). Set the RTP_Port_Max parameter to a smaller number (for example, RTP_Port_Min plus 8). There must be mappings for the every port number between RTP_Port_Min and RTP_Port_Max when using the Manual Configuration approach. Reserving 8 ports is safe, since it allows both lines to have two simultaneous calls with a port for RTP and RTCP.

Parameter Name	Description	Type	Default
Handle_VIA_received	If set to "yes", the PHONE ADAPTER will process the "received" parameter in the VIA header inserted by the server in a response to any one of its request. Else the parameter is ignored.	Bool	No
Handle_VIA_rport	If set to "yes", the PHONE ADAPTER will process the "rport" parameter in the VIA header inserted by the server in a response to any one of its request. Else the parameter is ignored.	Bool	No
Insert VIA received	Insert received parameter in VIA header in SIP responses if received from IP and VIA sent-by IP differ	Bool	No
Insert VIA rport	Insert rport parameter in VIA header in SIP responses if received-from port and VIA sent-by port differ	Bool	No
Substitute VIA addr	Use nat-mapped IP:port values in VIA header	Bool	No
Send Resp To Src Port	Send response to the request source port instead of the VIA sent-by port	Bool	No
STUN Server	STUN server to contact for NAT mapping discovery	FQDN	
STUN Enable	Enable the use of STUN to discover NAT mapping	Bool	No
STUN Test Enable	If enabled with <STUN Enable> = "yes" and a valid <STUN Server>, the PHONE ADAPTER will perform a NAT type discovery operation when first power on by contacting the configured STUN server. The result of the discovery will be reported in a Warning header in all subsequent REGISTER requests – "Warning: 399 Phone Adapter <stun type>", where <stun type> is one of the following: "Unknown NAT Type", "STUN Server Not Reachable", "STUN Server Not Responding", "Open Internet Detected", "Symmetric Firewall Detected", "Full Cone NAT Detected", "Restricted Cone NAT Detected", "Symmetric NAT Detected"; If the PHONE ADAPTER detects Symmetric Nat or Symmetric Firewall, Nat Mapping will be disabled (that is, no substitution of IP address and port with external IP address an nat-mapped port)	Bool	No
Ext IP	External IP address to substitute for the actual IP address of the unit in all outgoing SIP messages. If "0.0.0.0" is specified, no IP address substitution is performed.	IP	0.0.0.0

Ext SIP Port	External port to substitute for the actual SIP port of the unit in all outgoing SIP messages. If "0" is specified, no SIP port substitution is performed.	Port	0
Ext RTP Port Min	External port mapping of <RTP Port Min>. If this value is non-zero, the RTP port number in all outgoing SIP messages is substituted by the corresponding port value in the external RTP port range.	Port	0
NAT Mapping Enable	Enable the use of externally mapped of IP address and SIP/RTP ports in SIP messages. The mapping may be discovered by any of the supported methods.	Bool	No
NAT Keep Alive Enable	If set to "yes", the configured <NAT Keep Alive Msg> is sent periodically every <NAT Keep Alive Intvl> seconds.	Bool	No
NAT Keep Alive Msg	Contents of the keep-alive message to be sent to a given destination periodically to maintain the current NAT-mapping. It could be an empty string. If value is \$NOTIFY, a NOTIFY message is sent as keep alive. If value is \$REGISTER, a REGISTER message w/o Contact is sent.	Str31	\$NOTIFY
NAT Keep Alive Dest	Destination to send NAT keep alive messages to. If value is \$PROXY, it will be sent to the current proxy or outbound proxy	FQDN	\$PROXY
Use Outbound Proxy	Enable the use of <Outbound Proxy>. If set to "no", <Outbound Proxy> and <Use OB Proxy in Dialog> is ignored.	Bool	No
Outbound Proxy	SIP Outbound Proxy Server where all outbound requests are sent as the first hop.	FQDN	No
Use OB Proxy In Dialog	Whether to force SIP requests to be sent to the outbound proxy within a dialog. Ignored if <Use Outbound Proxy> is "no" or <Outbound Proxy> is empty	Bool	Yes
NAT Keep Alive Intvl	Interval between sending NAT-mapping keep alive message in sec	Uns16	15

4.6. Media and SDP (Session Description Protocol) Configuration

4.6.1. DTMF and Hookflash

By default, the PHONE ADAPTER sends DTMF to the far end using RFC2833-style "AVT tones". This method of conveying DTMF tones sends a representation of a tone (someone pressed the "7" key) to the RTP peer as a separate RTP audio codec, but with timing information synchronized with the speech audio codec. This method of DTMF conveyance works in most topologies, however in some environments, the service provider may have an application server which is not in the media path, or may be responsible for protocol conversion to a protocol or device which does not support AVT tones.

Likewise, hookflash events by default are handled internally by the PHONE ADAPTER and used to trigger supplementary services which are implemented on the PHONE ADAPTER. If a provider needs to convey a hookflash event to an application server to initiate a network-oriented feature, the PHONE ADAPTER is configurable to send these events.

The administrator can select a method for conveying DTMF and hookflash on a per-line basis. In addition, the administrator can also configure the MIME type (Content-Type header) used when conveying DTMF or hookflash in SIP INFO messages. The MIME type is set once for both lines.

DTMF Tx Method	Method to transmit DTMF signals to the far end: Inband = Send DTMF using the audio path; INFO = Use the SIP INFO method, AVT = Send DTMF as AVT events; Auto = Use Inband or AVT based on outcome of codec negotiation	Choice: {InBand, AVT, INFO Auto}	Auto
Hook Flash Tx Method	Select the method to signal Hook Flash events: • None: do not signal hook flash events • AVT: use RFC2833 AVT (event=16) • INFO: use SIP INFO method with the single line "signal = hf" in the message body. The MIME type for this message body is taken from the <Hook Flash MIME Type> paramter	Choice: {None, AVT, INFO}	None

DTMF Relay MIME Type	This is the MIME Type to be used in a SIP INFO message used to signal DTMF event.	Str31	application/dtmf-relay
Hook Flash MIME Type	This is the MIME Type to be used in a SIP INFO message used to signal hook flash event.	Str31	application/hook-flash

4.6.2. Codec and Audio Settings

The following parameters are used to enable or disable access to specific codecs, echo cancellation, and FAX support.

Parameter Name	Description	Type	Default
Preferred Codec	Select a preferred codec for all calls. However, the actual codec used in a call still depends on the outcome of the codec negotiation protocol. G711u, G711a, G726-16, G726-24, G726-32, G726-40, G729a, G723	Choice	G711u
Use Pref Codec Only	Only use the preferred codec for all calls. The call will fail if the far end does not support this codec.	Bool	No
Silence Supp Enable	Enable silence suppression so that silent audio frames are not transmitted	Bool	No
Echo Canc Enable	Enable the use of echo canceller	Bool	Yes
Echo Canc Adapt Enable	Enable echo canceller to adapt	Bool	Yes
Echo Supp Enable	Enable the use of echo suppressor. If <Echo Canc Enable> is "no", this parameter is ignored	Bool	Yes
G729a Enable ¹	Enable the use of G729a codec at 8 kbps.	Bool	Yes
G723 Enable ¹	Enable the use of G723 codec at 6.3 kbps	Bool	Yes
G726-16 Enable ¹	Enable the use of G726 codec at 16 kbps	Bool	Yes
G726-24 Enable ¹	Enable the use of G726 codec at 24 kbps	Bool	Yes
G726-32 Enable ¹	Enable the use of G726 codec at 32 kbps	Bool	Yes
G726-40 Enable ¹	Enable the use of G726 codec at 40 kbps	Bool	Yes
FAX Passthru Enable	*** This parameter has been removed. ***	Bool	Yes

FAX CED Detect Enable	Enable detection of FAX tone.	Bool	Yes
FAX CNG Detect Enable		Bool	Yes
FAX Passthru Codec	Codec to use for fax passthru	{G711u, G711a}	G711u
FAX Codec Symmetric	Force unit to use symmetric codec during FAX passthru	Bool	Yes
FAX Passthru Method	Choices: None / NSE / ReINVITE	Choice	NSE
FAX Process NSE		Bool	Yes
Release Unused Codec		Bool	Yes

Notes:

1. A codec resource is considered as allocated if it has been included in the SDP codec list of an active call, even though it eventually may not be the one chosen for the connection. So, if the G.729a codec is enabled and included in the codec list, that resource is tied up until the end of the call whether or not the call actually uses G.729a. If the G729a resource is already allocated and since only one G.729a resource is allowed per PHONE ADAPTER, no other low-bit-rate codec may be allocated for subsequent calls; the only choices are G711a and G711u. On the other hand, two G.723.1/G.726 resources are available per PHONE ADAPTER. Therefore it is important to disable the use of G.729a in order to guarantee the support of 2 simultaneous G.723/G.726 codec.

4.6.3. Dynamic Payload Types and SDP Codec Names

Note: You should only need to change the payload type mappings if you are interworking with a non-standard implementation.

Parameter Name	Description	Type	Default
NSE Dynamic Payload ^{1,2}	NSE dynamic payload type	Uns8	100
AVT Dynamic Payload ^{1,2}	AVT dynamic payload type	Uns8	101
G726r16 Dynamic Payload ^{1,2}	G726-16 dynamic payload type	Uns8	98
G726r24 Dynamic Payload ^{1,2}	G726-24 dynamic payload type	Uns8	97
G726r40 Dynamic Payload ^{1,2}	G726-40 dynamic payload type	Uns8	96
G729b Dynamic Payload ^{1,2}	G729b dynamic payload type	Uns8	99

Notes:

- Valid range is 96 – 127
- The configured dynamic payloads are used for outbound calls only where the PHONE ADAPTER presents the SDP offer. For inbound calls with a SDP offer, PHONE ADAPTER will follow the caller's dynamic payload type assignments

Parameter Name	Description	Type	Default
NSE Codec Name	NSE Codec name used in SDP	Str31	NSE
AVT Codec Name	AVT Codec name used in SDP	Str31	telephone-event
G711a Codec Name	G711a Codec name used in SDP	Str31	PCMA
G711u Codec Name	G711u Codec name used in SDP	Str31	PCMU
G726r16 Codec Name	G726-16 Codec name used in SDP	Str31	G726-16
G726r24 Codec Name	G726-24 Codec name used in SDP	Str31	G726-24
G726r32 Codec Name	G726-32 Codec name used in SDP	Str31	G726-32

G726r40 Codec Name	G726-40 Codec name used in SDP	Str31	G726-40
G729a Codec Name	G729a Codec name used in SDP	Str31	G729a
G729b Codec Name	G729b Codec name used in SDP	Str31	G729ab
G723 Codec Name	G723 Codec name used in SDP	Str31	G723

Notes:

1. PHONE ADAPTER uses the configured codec names in its outbound SDP
2. PHONE ADAPTER ignores the codec names in incoming SDP for standard payload types (0 – 95).
3. For dynamic payload types, PHONE ADAPTER identifies the codec by the configured codec names. Comparison is case-insensitive.

4.6.4. Secure Media Implementation:

A secure call is established in two stages. The first stage is no different from a normal call setup. Right after the call is established in the normal way with both sides ready to stream RTP packets, the second stage starts where the two parties exchange information to determine if the current call can switch over to the secure mode. The information is transported by base64 encoding and embedding in the message body of SIP INFO requests and responses with a proprietary format. If the second stage is successful, the PHONE ADAPTER will play a special “Secure Call Indication Tone” for short while to indicate to both parties that the call is secured and that RTP traffic in both directions are encrypted. If the user has a CIDCW capable phone and CIDCW service is enabled, then the CID will be updated with the information extracted from the Mini-Certificate received from the other end. The Name field of this CID will be prepended with a '\$' symbol.

The second stage in setting up a secure call can be further divided into two steps. Step 1 the caller sends a “Caller Hello” message (base64 encoded and embedded in the message body of a SIP INFO request) to the called party with the following information:

- Message ID (4B)
- Version and flags (4B)
- SSRC of the encrypted stream (4B)
- Mini-Certificate (252B)

Upon receiving the Caller Hello, the callee responds with a Callee Hello message (base64 encoded and embedded in the message body of a SIP response to the caller’s INFO request) with similar information, if the Caller Hello message is valid. The caller then examines the Callee Hello and proceeds to step 2 if the message is valid. In step 2 the caller sends the “Caller Final” message to the callee with the following information:

- Message ID (4B)
- Encrypted Master Key (16B or 128b)
- Encrypted Master Salt (16B or 128b)

With the master key and master salt encrypted with the public key from the callee’s mini-certificate. The master key and master salt are used by both ends for the derivation of session keys for encrypting subsequent RTP packets. The callee then responds with a Callee Final message (which is an empty message).

A Mini-Certificate contains the following information:

- User Name (32B)
- User ID or Phone Number (16B)

- Expiration Date (12B)
- Public Key (512b or 64B)
- Signature (1024b or 512B)

The signing agent is implicit and must be the same for all PHONE ADAPTER's that intended to communicate securely with each other. The public key of the signing agent is pre-configured into the PHONE ADAPTER's by the administrator and will be used by the PHONE ADAPTER to verify the Mini-Certificate of its peer. The Mini-Certificate is valid if a) it has not expired, and b) its signature checks out.

User Interface

The PHONE ADAPTER can be set up such that all outbound calls are secure calls by default, or not secure by default. If outbound calls are secure by default, user has the option to disable security when making the next call by dialing *19 before dialing the target number. If outbound calls are not secure by default, user has the option to make the next outbound call secure by dialing *18 before dialing the target number. On the other hand, user cannot force inbound calls to be secure or not secure; it is at the mercy of the caller whether he/she enables security or not for that call.

If the call successfully switches to the secure mode, both parties will hear the "Secure Call Indication Tone" for a short while and the CID will be updated with the Name and Number extracted from the Mini-Certificate sent by the other party, provided CIDCW service and equipment are available: the CID Name in this case will have a '\$' sign inserted at the beginning. The callee should check the name and number again to ensure the identity of the caller. The caller should also double check the name and number of the callee to make sure this is what he/she expects. Note that the PHONE ADAPTER will not switch to secure mode if the callee's CID Number from its Mini-Certificate does not agree with the user-id used in making the outbound call: the caller's PHONE ADAPTER will perform this check after receiving the callee's Mini-Certificate.

Service Provider Requirements

The PHONE ADAPTER Mini-Certificate (MC) has a 512-bit public key used for establishing secure calls. The administrator must provision each subscriber of the secure call service with an MC and the corresponding 512-bit private key. The MC is signed with a 1024-bit private key of the service provider who acts as the CA of the MC. The 1024-bit public key of the CA signing the MC must also be provisioned to each subscriber. The CA public key is used by the PHONE ADAPTER to verify the MC received from the other end. If the MC is invalid, the PHONE ADAPTER will not switch to secure mode. The MC and the 1024-bit CA public key are concatenated and base64 encoded into the single parameter <Mini Certificate>. The 512-bit private key is base64 encoded into the <SRTP Private Key> parameter, which should be hidden from the PHONE ADAPTER's web interface like a password.

Since the secure call establishment relies on exchange of information embedded in message bodies of SIP INFO requests/responses, the service provider must make sure that their infrastructure will allow the SIP INFO messages to pass through with the message body unmodified.

Linksys provides a configuration tool called gen_mc for the generation of MC and private keys with the following syntax:

```
gen_mc <ca-key> <user-name> <user-id> <expire-date>
```

Where:

- ca-key is a text file with the base64 encoded 1024-bit CA private/public key pairs for signing/verifying the MC, such as
9CC9aYU1X5lJuU+EBZmi3AmcqE9U1LxEOGwopaGyGOh3VyhKgi6JaVtQZt87PiJINKW8XQj3B9Qq

e3VgYxWCQNa335YCnDsenASeBxuMIEaBCYd11fVEodJZOGwXwfAde0MhcbD0kj7LVlzcSytK2TZ
YTccnZ75TuTjj13qvYs=
5nEtOrkCa84/mEwl3D9tSvVLyIiwQ+u/Hd+C8u5SNk7hsAUZaA9TqH8lw0J/lqSrsf6scsmundY5j7Z5m
K5J9uBxSB8t8vamFGD0pF4zhNtbrVvIXKI9kmp4vph1C5jzO9gDfs3MF+zjyYrVUFdM+pXtDBxmM+f
GUfrpAuXb7/k=

- user-name is the name of the subscriber, such as “Joe Smith”. Maximum length is 32 characters
- user-id is the user-id of the subscriber and must be exactly the same as the user-id used in the INVITE when making the call, such as “14083331234”. Maximum length is 16 characters.
- expire-date is the expiration date of the MC, such as “00:00:00 1/1/34” (34=2034). Internally the date is encoded as a fixed 12B string: 000000010134

The tool generates the <Mini Certificate> and <SRTP Private Key> parameters that can be provisioned to the PHONE ADAPTER.

For Example:

gen_mc ca_key “Joe Smith” 14085551234 “00:00:00 1/1/34”

Produces:

<Mini Certificate>

Sm9IIFNtaXR0AAAAAAAAAAAAAAAAAAAAAAAAAAAAAAxNDA4NTU1MTIzNAAAAAAAAAMDAwM
DAwMDEwMTM0OvJakde2vVMF3Rw4pPXL7IAglagMpbLSAG2+++YISqt198Cp9rP/xMGFfoPmDK
Gx6JFtkQ5sxLcuwgxpXpkExvpZKIYlpsb28L4Rhg5qZA+Gqj1hDFCmG6dffZ9SjhxES767G0JIS+N8l
QBLr0AuemotknSjjOy8c+1ITCd2t44Mh0vmwNg4fDck2YdmTMBR516xJt4/uQ/LJQIn2kwqIm7scDvIl5
k232EvvVtCK0AYa4eWd6fQOPiESCO9CC9aYU1X5IJU+EBZmi3AmcqE9U1LxEOGwopaGyGOh3
VyhKgi6JaVtQZt87PiJINKW8XQj3B9Qqe3VgYxWCQNa335YCnDsenASeBxuMIEaBCYd11fVEodJZ
OGwXwfAde0MhcbD0kj7LVlzcSytK2TZYTccnZ75TuTjj13qvYs=

<SRTP Private Key>

b/DWc96X4YQraCnYzI5en1CIUhVQQqrvcR6Qd/8R52IEvJjOw/e+Klm4XiiFEPaKmU8UbooxKG36SEd
Kusp0AQ==

Mini Certificate	Base64 encoded of Mini-Certificate concatenated with the 1024-bit public key of the CA signing the MC of all subscribers in the group.	Str508	Empty
SRTP Private Key	Base64 encoded of the 512-bit private key per subscriber for establishment of a secure call.	Str88	Empty

4.6.5. Outbound Call Codec Selection Codes:

The User can use additional feature codes on the PHONE ADAPTER to force or prefer specific codecs. These codes are automatically appended to the dial-plan. There is no need to include them explicitly in dial-plan

Parameter Name	Description	Type	Default
Prefer G711u Code	Dialing code will make this codec the preferred codec for the associated call.	ActCode	*017110
Force G711u Code	Dialing code will make this codec the only codec that can be used for the associated call.	ActCode	*027110
Prefer G711a Code	Dialing code will make this codec the preferred codec for the associated call.	ActCode	*017111
Force G711a Code	Dialing code will make this codec the only codec that can be used for the associated call.	ActCode	*027111

Prefer G723 Code	Dialing code will make this codec the preferred codec for the associated call.	ActCode	*01723
Force G723 Code	Dialing code will make this codec the only codec that can be used for the associated call.	ActCode	*02723
Prefer G726r16 Code	Dialing code will make this codec the preferred codec for the associated call.	ActCode	*0172616
Force G726r16 Code	Dialing code will make this codec the only codec that can be used for the associated call.	ActCode	*0272616
Prefer G726r24 Code	Dialing code will make this codec the preferred codec for the associated call.	ActCode	*0172624
Force G726r24 Code	Dialing code will make this codec the only codec that can be used for the associated call.	ActCode	*0272624
Prefer G726r32 Code	Dialing code will make this codec the preferred codec for the associated call.	ActCode	*0172632
Force G726r32 Code	Dialing code will make this codec the only codec that can be used for the associated call.	ActCode	*0272632
Prefer G726r40 Code	Dialing code will make this codec the preferred codec for the associated call.	ActCode	*0172640
Force G726r40 Code	Dialing code will make this codec the only codec that can be used for the associated call.	ActCode	*0272640
Prefer G729a Code	Dialing code will make this codec the preferred codec for the associated call.	ActCode	*01729
Force G729a Code	Dialing code will make this codec the only codec that can be used for the associated call.	ActCode	*02729

4.7. Supplementary Services

Each line of the PHONE ADAPTER has settings which enable or disable each of the supplementary services implemented directly in the PHONE ADAPTER. The expected behavior when a specific service is enabled is described in Section 5.

The PHONE ADAPTER provides native support of a large set of enhanced or supplementary services. All of these services are optional. The parameters listed in the following table are used to enable or disable a specific supplementary service. A supplementary service should be disabled if a) the user has not subscribed for it, or b) the Service Provider intends to support similar service using other means than relying on the PHONE ADAPTER.

Parameter Name	Description	Type	Default
Call Waiting Serv	Enable Call Waiting Service	Bool	Yes
Block CID Serv	Enable Block Caller ID Service	Bool	Yes
Block ANC Serv	Enable Block Anonymous Calls Service	Bool	Yes
Dist Ring Serv	Enable Distinctive Ringing Service	Bool	Yes
Cfwd All Serv	Enable Call Forward All Service	Bool	Yes
Cfwd Busy Serv	Enable Call Forward Busy Service	Bool	Yes
Cfwd No Ans Serv	Enable Call Forward No Answer Service	Bool	Yes
Cfwd Sel Serv	Enable Call Forward Selective Service	Bool	Yes
Cfwd Last Serv	Enable Forward Last Call Service	Bool	Yes
Block Last Serv	Enable Block Last Call Service	Bool	Yes
Accept Last Serv	Enable Accept Last Call Service	Bool	Yes
DND Serv	Enable Do Not Disturb Service	Bool	Yes
CID_Serv	Enable Caller ID Service	Bool	Yes

CWCID Serv	Enable Call Waiting Caller ID Service	Bool	Yes
Call Return Serv	Enable Call Return Service	Bool	Yes
Call Back Serv	Enable Call Back Service	Bool	Yes
Three Way Call Serv ¹	Enable Three Way Calling Service	Bool	Yes
Three Way Conf Serv ^{1,2}	Enable Three Way Conference Service	Bool	Yes
Attn Transfer Serv ^{1,2}	Enable Attended Call Transfer Service	Bool	Yes
Unattn Transfer Serv	Enable Unattended (Blind) Call Transfer Service	Bool	Yes
MWI Serv ³	Enable MWI Service	Bool	Yes
VMWI Serv	Enable VMWI Service (FSK)	Bool	Yes
Speed Dial Serv	Enable Speed Dial Service	Bool	Yes
Secure Call Serv	Enable Secure Call Service	Bool	Yes
Referral Serv	Enable Referral Service. See <Referral Services Codes> for more details	Bool	Yes
Feature Dial Serv	Enable Feature Dial Service. See <Feature Dial Services Codes> for more details	Bool	Yes

Notes:

1. Three Way Calling is required for Three Way Conference and Attended Transfer.
2. Three Way Conference is required for Attended Transfer.
3. MWI is available only if a Voice Mail Service is set-up in the deployment.

4.7.1. Supplementary Services activated internally

Once Supplementary Services on the PHONE ADAPTER are Enabled, the services can be activated or deactivated dynamically by dialing specific (configurable) dial strings. For example, the default dial string to activate or deactivate most features is a "*" character followed by a two digit code. The following table lists the parameters which set these dial strings used internally by the PHONE ADAPTER. If a provider wishes to offer a service which is activated or deactivated in an application server in their network instead of internally in the PHONE ADAPTER, the dial pattern for that service should NOT be present in these configuration parameters.

Parameter Name	Description	Type	Default
Call Return Code	Call the last caller.	ActCode	*69
Blind Transfer Code	Blind transfer current call to the target specified after the activation code	ActCode	*98
Cfwd All Act Code	Forward all calls to the target specified after the activation code	ActCode	*72
Cfwd All Deact Code	Cancel call forward all	ActCode	*73
Cfwd Busy Act Code	Forward busy calls to the target specified after the activation code	ActCode	*90
Cfwd Busy Deact Code	Cancel call forward busy	ActCode	*91
Cfwd No Ans Act Code	Forward no-answer calls to the target specified after the activation code	ActCode	*92
Cfwd No Ans Deact Code	Cancel call forward no-answer	ActCode	*93
Cfwd Last Act Code	Forward the last inbound or outbound calls to the target specified after the activation code	ActCode	*63

Cfwd Last Deact Code	Cancel call forward last	ActCode	*83
Block Last Act Code	Block the last inbound call	ActCode	*60
Block Last Deact Code	Cancel blocking of the last inbound call	ActCode	*80
Accept Last Act Code	Accept the last outbound call. Let it ring through when DND or Call Forward All is in effect	ActCode	*64
Accept Last Deact Code	Cancel Accept Last	ActCode	*84
Call Back Act Code	Callback when the last outbound call is not busy	ActCode	*66
Call Back Deact Code	Cancel callback	ActCode	*86
CW_Act_Code	Enable Call Waiting on all calls	ActCode	*56
CW_Deact_Code	Disable Call Waiting on all calls	ActCode	*57
CW_Per_Call_Act_Code	Enable Call Waiting for the next call	ActCode	*71
CW_Per_Call_Deact_Code	Disable Call Waiting for the next call	ActCode	*70
Block_CID_Act_Code	Block CID on all outbound calls	ActCode	*67
Block_CID_Deact_Code	Unblock CID on all outbound calls	ActCode	*66
Block_CID_Per_Call_Act_Code	Block CID on the next outbound call	ActCode	*81
Block_CID_Per_Call_Deact_Code	Unblock CID on the next inbound call	ActCode	*82
Block_ANC_Act_Code	Block all anonymous calls	ActCode	*77
Block_ANC_Deact_Code	Unblock all anonymous calls	ActCode	*87
DND_Act_Code	Enable Do Not Disturb	ActCode	*78
DND_Deact_Code	Disable Do Not Disturb	ActCode	*79
CID_Act_Code	Enable Caller-ID Generation	ActCode	*65
CID_Deact_Code	Disable Call-ID Generation	ActCode	*85
CWCID_Act_Code	Enable Call Waiting Caller-ID generation	ActCode	*25
CWCID_Deact_Code	Disable Call Waiting Caller-ID generation	ActCode	*45
Dist_Ring_Act_Code	Enable Distinctive Ringing	ActCode	*61
Dist_Ring_Deact_Code	Disable Distinctive Ringing	ActCode	*81
Speed Dial Act Code	Assign a speed dial number	ActCode	*74
Secure All Call Act Code	Make all outbound calls secure	ActCode	*16
Secure No Call Act Code	Make all outbound calls not secure	ActCode	*17
Secure One Call Act Code	Make the next outbound call secure. This operation is redundant if all outbound calls are secure by default.	ActCode	*18
Secure One Call Deact Code	Make the next outbound call not secure. This operation is redundant if all outbound calls are not secure by default.	ActCode	*19

In addition to the dynamic activation and deactivation codes, the following parameters control the default activation or deactivation of internal parameters.

Parameter Name	Description	Type	Default
CW Setting	Call Waiting on/off by default for all calls	Bool	Yes
Block CID Setting	Block Caller ID on/off by default for all calls	Bool	No
Block ANC Setting	Block Anonymous Calls on or off	Bool	No
DND Setting	Do Not Disturb on or off	Bool	No
CID Setting	Caller ID Generation on or off	Bool	Yes
CWCID Setting	Call Waiting Caller ID Generation on or off	Bool	Yes
Dist Ring Setting	Distinctive Ring on or off	Bool	Yes

Secure Call Setting	If yes, all outbound calls are secure calls by default	Bool	No
---------------------	--	------	----

4.7.2. Call Forwarding Implemented internally

The PHONE ADAPTER supports local call forwarding services (Call Forward All, Call Forward Busy, Call Forward No Answer, and Selective Call Forwarding for up to 8 numbers).

Parameter Name	Description	Type	Default
Cfwd All Dest	Forward number for Call Forward All Service	Phone	
Cfwd Busy Dest	Forward number for Call Forward Busy Service	Phone	
Cfwd No Ans Dest	Forward number for Call Forward No Answer Service	Phone	
Cfwd No Ans Delay	Delay in sec before Call Forward No Answer triggers	Uns8	20
Cfwd Sel1 Caller	Caller number pattern to trigger Call Forward Selective 1	PhTmpl	
Cfwd Sel2 Caller	Caller number pattern to trigger Call Forward Selective 2	PhTmpl	
Cfwd Sel3 Caller	Caller number pattern to trigger Call Forward Selective 3	PhTmpl	
Cfwd Sel4 Caller	Caller number pattern to trigger Call Forward Selective 4	PhTmpl	
Cfwd Sel5 Caller	Caller number pattern to trigger Call Forward Selective 5	PhTmpl	
Cfwd Sel6 Caller	Caller number pattern to trigger Call Forward Selective 6	PhTmpl	
Cfwd Sel7 Caller	Caller number pattern to trigger Call Forward Selective 7	PhTmpl	
Cfwd Sel8 Caller	Caller number pattern to trigger Call Forward Selective 8	PhTmpl	
Cfwd Sel1 Dest	Forward number for Call Forward Selective 1	Phone	
Cfwd Sel2 Dest	Forward number for Call Forward Selective 2	Phone	
Cfwd Sel3 Dest	Forward number for Call Forward Selective 3	Phone	
Cfwd Sel4 Dest	Forward number for Call Forward Selective 4	Phone	
Cfwd Sel5 Dest	Forward number for Call Forward Selective 5	Phone	
Cfwd Sel6 Dest	Forward number for Call Forward Selective 6	Phone	
Cfwd Sel7 Dest	Forward number for Call Forward Selective 7	Phone	
Cfwd Sel8 Dest	Forward number for Call Forward Selective 8	Phone	
Block Last Caller	ID of caller blocked via the "Block Last Caller" service	Phone	
Accept Last Caller	ID of caller accepted via the "Accept Last Caller" service	Phone	
Cfwd Last Caller	The Caller number that is actively forwarded to <Cfwd Last Dest> by using the Call Forward Last activation code	Phone	
Cfwd Last Dest	Forward number for the <Cfwd Last Caller>	Phone	

4.7.3. Supplementary Services implemented in the service provider network

For services which are activated or deactivated in the service provider network (for example in an application server), instead of internally in the PHONE ADAPTER, The Feature_Dial_Services_Codes and Referral_Services_Codes parameters contain a list of dial strings that correspond to feature codes in the network after which the PHONE ADAPTER needs to collect a target number. These codes are automatically appended to the dial plan, so there is no need to explicitly include them in the dial plan. For example, if call forwarding is implemented in the network, the code to activate call forwarding and collect the target number should be included in the Feature_Dial_Services_Codes parameter, but the code to deactivate call forwarding should not (since it does not require collection of a target phone number).

Feature Dial Services Codes

One or more *code can be configured into this parameter, such as *72, or *72|*74|*67|*82, etc. Max total length is 79 chars. This parameter applies when the user has a dial tone (1st or 2nd dial tone). Enter *code (and the following target number according to current dial plan) entered at the dial tone triggers the PHONE ADAPTER to call the target number prepended by the *code. For example, after user dials *72, the PHONE ADAPTER plays a prompt tone awaiting the user to enter a valid target number. When a complete number is entered, the PHONE ADAPTER sends a INVITE to *72<target_number> as in a normal call. This feature allows the proxy to process features like call forward (*72) or BLock Caller ID (*67).

Notes:

- The *codes should not conflict with any of the other vertical service codes internally processed by the PHONE ADAPTER. You can empty the corresponding *code that you do not want to PHONE ADAPTER to process.

- You can add a parameter to each *code in "Features Dial Services Codes" to indicate what tone to play after the *code is entered, such as *72`c`|*67`p`. Below are a list of allowed tone parameters (note the use of back quotes surrounding the parameter w/o spaces)

`c` = <Cfwd Dial Tone>

`d` = <Dial Tone>

`m` = <MWI Dial Tone>

`o` = <Outside Dial Tone>

`p` = <Prompt Dial Tone>

`s` = <Second Dial Tone>

`x` = No tones are place, x is any digit not used above

If no tone parameter is specified, the PHONE ADAPTER plays Prompt tone by default.

- If the *code is not to be followed by a phone number, such as *73 to cancel call forwarding, do not include it in this parameter. In that case, simply add that *code in the dial plan and the PHONE ADAPTER will send INVITE *73@..... as usual when user dials *73.

Referral Services Codes

One or more *code can be configured into this parameter, such as *98, or *97|*98|*123, etc. Max total length is 79 chars. This parameter applies when the user places the current call on hold (by Hook Flash) and is listening to 2nd dial tone. Each *code (and the following valid target number according to current dial plan) entered on the 2nd dial-tone triggers the PHONE ADAPTER to perform a blind transfer to a target number that is prepended by the service *code. For example, after the user dials *98, the PHONE ADAPTER plays a special dial tone called the "Prompt Tone" while waiting for the user the enter a target number (which is checked according to dial plan as in normal dialing). When a complete number is entered, the PHONE ADAPTER sends a blind REFER to the holding party with the Refer-To target equals to *98<target_number>. This feature allows the PHONE ADAPTER to "hand off" a call to an application server to perform further processing, such as call park.

Notes:

- The *codes should not conflict with any of the other vertical service codes internally processed by the PHONE ADAPTER. You can empty the corresponding *code that you do not want to PHONE ADAPTER to process.

4.8. Dial Plan Configuration

The PHONE ADAPTER allows each line to be configured with a distinct dial plan. The dial plan specifies how to interpret digit sequences dialed by the user, and how to convert those sequences into an outbound dial string.

The PHONE ADAPTER syntax for the dial plan closely resembles the corresponding syntax specified by MGCP and MEGACO. Some extensions are added that are useful in an end-point.

The dial plan functionality is regulated by the following configurable parameters:

- Interdigit_Long_Timer
- Interdigit_Short_Timer
- Dial_Plan ([1] and [2])
- Enable_IP_Dialing

Other timers are configurable via parameters, but do not directly pertain to the dial plan itself. They are discussed elsewhere in this document.

Interdigit Long Timer:

ParName:	Interdigit_Long_Timer
Default:	10

The Interdigit_Long_Timer specifies the default maximum time (in seconds) allowed between dialed digits, when no candidate digit sequence is as yet complete (see discussion of Dial_Plan parameter for an explanation of candidate digit sequences).

Interdigit Short Timer:

ParName:	Interdigit_Short_Timer
Default:	3

The Interdigit_Short_Timer specifies the default maximum time (in seconds) allowed between dialed digits, when at least one candidate digit sequence is complete as dialed (see discussion of Dial_Plan parameter for an explanation of candidate digit sequences).

Dial Plan[1] and Dial Plan[2]:

ParName:	Dial_Plan[1] and Dial_Plan[2]
Default:	(*xx [3469]11 0 00 <:1408>[2-9]xxxxxx 1[2-9]xx[2-9]xxxxxx 011x.)

The Dial_Plan parameters contain the actual dial plan scripts for each of lines 1 and 2.

Dial Plan Digit Sequences:

The plans contain a series of digit sequences, separated by the '|' character. The collection of sequences is enclosed in parentheses, '(' and ')'.

When a user dials a series of digits, each sequence in the dial plan is tested as a possible match. The matching sequences form a set of candidate digit sequences. As more digits are entered by the user, the set of candidates diminishes until only one or none are valid.

Any one of a set of terminating events triggers the PHONE ADAPTER to either accept the user-dialed sequence, and transmit it to initiate a call, or else reject it as invalid. The terminating events are:

- No candidate sequences remain: the number is rejected.
- Only one candidate sequence remains, and it has been matched completely: the number is accepted and transmitted after any transformations indicated by the dial plan, unless the sequence is barred by the dial plan (barring is discussed later), in which case the number is rejected.
- A timeout occurs: the digit sequence is accepted and transmitted as dialed if incomplete, or transformed as per the dial plan if complete.
- An explicit 'send' (user presses the '#' key): the digit sequence is accepted and transmitted as dialed if incomplete, or transformed as per the dial plan if complete.

The timeout duration depends on the matching state. If no candidate sequences are as yet complete (as dialed), the Interdigit_Long_Timeout applies. If a candidate sequence is complete, but there exists one or more incomplete candidates, then the Interdigit_Short_Timeout applies.

White space is ignored, and may be used for readability.

Digit Sequence Syntax:

Each digit sequence within the dial plan consists of a series of elements, which are individually matched to the keys pressed by the user. Elements can be one of the following:

- Individual keys '0', '1', '2' . . . '9', '*', '#'.
- The letter 'x' matches any one numeric digit ('0' .. '9')
- A subset of keys within brackets (allows ranges): '[' set ']' (e.g. [389] means '3' or '8' or '9')
 - Numeric ranges are allowed within the brackets: digit '-' digit (e.g. [2-9] means '2' or '3' or ... or '9')
 - Ranges can be combined with other keys: e.g. [235-8*] means '2' or '3' or '5' or '6' or '7' or '8' or '*'.

Element repetition:

Any element can be repeated zero or more times by appending a period ('.' character) to the element. Hence, "01." matches "0", "01", "011", "0111", ... etc.

Subsequence Substitution:

A subsequence of keys (possibly empty) can be automatically replaced with a different subsequence using an angle bracket notation: '<' dialed-subsequence ':' transmitted-subsequence '>'. So, for example, "<8:1650>xxxxxx" would match "85551212" and transmit "16505551212".

Intersequence Tones:

An "outside line" dial tone can be generated within a sequence by appending a ',' character between digits. Thus, the sequence "9, 1xxxxxxx" sounds an "outside line" dial tone after the user presses '9', until the '1' is pressed.

Number Barring:

A sequence can be barred (rejected) by placing a '!' character at the end of the sequence. Thus, "1900xxxxxx!" automatically rejects all 900 area code numbers from being dialed.

Interdigit Timer Master Override:

The long and short interdigit timers can be changed in the dial plan (affecting a specific line) by preceding the entire plan with the following syntax:

- Long interdigit timer: 'L' ':' delay-value '
- Short interdigit timer: 'S' ':' delay-value '

Thus, "L=8,(. . .)" would set the interdigit long timeout to 8 seconds for the line associated with this dial plan. And, "L:8,S:4,(. . .)" would override both the long and the short timeout values.

Local Timer Overrides:

The long and short timeout values can be changed for a particular sequence starting at a particular point in the sequence. The syntax for long timer override is: 'L' delay-value ' '. Note the terminating space character. The specified delay-value is measured in seconds. Similarly, to change the short timer override, use: 'S' delay-value <space>.

These overrides are especially useful to terminate dialing in countries with predictable but variable length numbering plans, or to provide an exception when a rule with fewer digits is known to override a rule waiting for more digits. For example, assuming a generic international calling sequence of 011xxxxxxx. in North America, the PHONE ADAPTER can be configured to complete dialing to France after the country code and exactly 10 digits using 01133xxxxxxxxS:0 as a dial plan digit sequence. When this sequence matches, it overrides the short interdigit timer, causing an immediate call. If the S:0 had been absent, the PHONE ADAPTER would wait for the short interdigit timer to expire before placing the call.

Pause:

A sequence may require an explicit pause of some duration before continuing to dial digits, in order for the sequence to match. The syntax for this is similar to the timer override syntax: 'P' delay-value <space>. The delay-value is measured in seconds.

This syntax allows for the implementation of Hot-Line and Warm-Line services. To achieve this, one sequence in the plan must start with a pause, with a 0 delay for a Hot Line, and a non-zero delay for a Warm Line.

Implicit sequences:

The PHONE ADAPTER implicitly appends the vertical code sequences entered in the Regional parameter settings to the end of the dial plan for both line 1 and line 2. Likewise, if Enable_IP_Dialing is enabled, then ip dialing is also accepted on the associated line.

Maximum Length

Each dial plan cannot exceed 2047 bytes, after all configured vertical codes have been added to the Dial_Plan parameter.

Examples:

The following dial plan accepts only US-style 1 + area-code + local-number, with no restrictions on the area code and number.

```
( 1 xxx xxxxxxxx )
```

The following also allows 7-digit US-style dialing, and automatically inserts a 1 + 212 (local area code) in the transmitted number.

```
( 1 xxx xxxxxxxx | <:1212> xxxxxxxx )
```

For an office environment, the following plan requires a user to dial 8 as a prefix for local calls and 9 as a prefix for long distance. In either case, an “outside line” tone is played after the initial 8 or 9, and neither prefix is transmitted when initiating the call.

```
( <9,:> 1 xxx xxxxxxxx | <8,:1212> xxxxxxxx )
```

The following allows only placing international calls (011 call), with an arbitrary number of digits past a required 5 digit minimum, and also allows calling an international call operator (00). In addition, it lengthens the default short interdigit timeout to 4 seconds.

```
S:4, ( 00 | 011 xxxxxx x. )
```

The following allows only US-style 1 + area-code + local-number, but disallows area codes and local numbers starting with 0 or 1. It also allows 411, 911, and operator calls (0).

```
( 0 | [49]11 | 1 [2-9]xx [2-9]xxxxxxx )
```

The following allows US-style long distance, but blocks 9xx area codes.

```
( 1 [2-8]xx [2-9]xxxxxxx )
```

The following allows arbitrary long distance dialing, but explicitly blocks the 947 area code.

```
( 1 947 xxxxxxxx ! | 1 xxx xxxxxxxx )
```

The following implements a Hot Line phone, which automatically calls 1 212 5551234.

```
( S0 <:12125551234> )
```

The following provides a Warm Line to a local office operator (1000) after 5 seconds, unless a 4 digit extension is dialed by the user.

(P5 <:1000> | xxxxx)

Explanation of Default Dial Plan

The Default Dial Plan script for each line is:

```
("*xx|[3469]11|0|00|[2-9]xxxxxx|1xxx[2-9]xxxxxx|xxxxxxxxxxxxx.)"
```

Dial Plan Entry	Functionality
*xx	Allow arbitrary 2 digit star code
[3469]11	Allow x11 sequences
0	Operator
00	Int'l Operator
[2-9]xxxxxx	US "local" number
1xxx[2-9]xxxxxx	US 1 + 10-digit long distance number
xxxxxxxxxxxxx.	Everything else (Int'l long distance, FWD, ...)

IP Dialing

If IP dialing is enabled, one can dial [user-id@]a.b.c.d[:port], where '@', '.', and ':' are dialed by entering "*", user-id must be numeric (like a phone number) and a, b, c, d must be between 0 and 255, and port must be larger than 255. If port is not given, 5060 is used. Port and User-Id are optional. If the user-id portion matches a pattern in the dial plan, then it is interpreted as a regular phone number according to the dial plan. The INVITE message, however, is still sent to the outbound proxy if it is enabled.

4.8.1. Speed Dialing Settings

If assigned, Speed Dials enable a user to dial a single digit from 2 through 9 and then the "#" character, to dial the number configured in the PHONE ADAPTER. Speed dials are specified per line.

Parameter Name	Description	Type	Default
Speed Dial 2	Target phone number (or URL) assigned to speed dial "2"	Phone	
Speed Dial 3	Target phone number (or URL) assigned to speed dial "3"	Phone	
Speed Dial 4	Target phone number (or URL) assigned to speed dial "4"	Phone	
Speed Dial 5	Target phone number (or URL) assigned to speed dial "5"	Phone	
Speed Dial 6	Target phone number (or URL) assigned to speed dial "6"	Phone	
Speed Dial 7	Target phone number (or URL) assigned to speed dial "7"	Phone	
Speed Dial 8	Target phone number (or URL) assigned to speed dial "8"	Phone	
Speed Dial 9	Target phone number (or URL) assigned to speed dial "9"	Phone	

4.9. Progress Tone and Ring Configuration

The progress tones and ring tones on the PHONE ADAPTER are extremely configurable. There are 18 configurable call progress tones, 8 configurable ringing cadences, and 8 configurable call waiting cadences. Progress tones and Ring cadences are configured using FreqScripts and CadScripts respectively (described in Section 4.1).

4.9.1. Distinctive Ring and Other Ring Settings

Distinctive Ringing and Distinctive Call Waiting Tones can be associated with specific callers configured directly into the PHONE ADAPTER, by setting the appropriate callers in the Ring_n_Caller parameters. The Ring_1_Caller parameter specifies which callers will trigger ring cadence 1, and so forth. If a provider wishes to offer a distinctive ringing service by providing hints from the network, the provider can insert an Alert-Info SIP header into incoming calls. If the value in the Alert-Info header matches one of the strings in the Ring_n_Name set of parameters, the corresponding ring cadence will be used.

In addition to ordinary and distinctive rings, there are number of other situations where the PHONE ADAPTER can provide a short burst of ringing. These ring settings are described below.

Parameter Name	Description	Type	Default
Ring 1 Caller	Caller number pattern to play Distinctive Ring/CWT 1	PhTmpl	
Ring 2 Caller	Caller number pattern to play Distinctive Ring/CWT 2	PhTmpl	
Ring 3 Caller	Caller number pattern to play Distinctive Ring/CWT 3	PhTmpl	
Ring 4 Caller	Caller number pattern to play Distinctive Ring/CWT 4	PhTmpl	
Ring 5 Caller	Caller number pattern to play Distinctive Ring/CWT 5	PhTmpl	
Ring 6 Caller	Caller number pattern to play Distinctive Ring/CWT 6	PhTmpl	
Ring 7 Caller	Caller number pattern to play Distinctive Ring/CWT 7	PhTmpl	
Ring 8 Caller	Caller number pattern to play Distinctive Ring/CWT 8	PhTmpl	
Default Ring	Default ringing pattern, 1 – 8, for all callers	{1,2,3,4,5,6,7,8}	1
Default CWT	Default CWT pattern, 1 – 8, for all callers	{1,2,3,4,5,6,7,8}	1
Hold Reminder Ring	Ring pattern for reminder of a holding call when the phone is on-hook	{1,2,3,4,5,6,7,8, None}	None
Call Back Ring	Ring pattern for call back notification	{1,2,3,4,5,6,7,8}	None
Ring1 Name	Name in an INVITE's Alert-Info Header to pick distinctive ring/CWT 1 for the inbound call	Str31	Bellcore-r1
Ring2 Name	Name in an INVITE's Alert-Info Header to pick distinctive ring/CWT 2 for the inbound call	Str31	Bellcore-r2
Ring3 Name	Name in an INVITE's Alert-Info Header to pick distinctive ring/CWT 3 for the inbound call	Str31	Bellcore-r3
Ring4 Name	Name in an INVITE's Alert-Info Header to pick distinctive ring/CWT 4 for the inbound call	Str31	Bellcore-r4
Ring5 Name	Name in an INVITE's Alert-Info Header to pick distinctive ring/CWT 5 for the inbound call	Str31	Bellcore-r5
Ring6 Name	Name in an INVITE's Alert-Info Header to pick distinctive ring/CWT 6 for the inbound call	Str31	Bellcore-r6
Ring7 Name	Name in an INVITE's Alert-Info Header to pick distinctive ring/CWT 7 for the inbound call	Str31	Bellcore-r7

Ring8 Name	Name in an INVITE's Alert-Info Header to pick distinctive ring/CWT 8 for the inbound call	Str31	Bellcore-r8
Cfwd Ring Splash Len ²	Duration of ring splash when a call is forwarded (0 – 10.0s)	Time3	0
Cblk Ring Splash Len ²	Duration of ring splash when a call is blocked (0 – 10.0s)	Time3	0
VMWI Ring Splash Len	Duration of ring splash when new messages arrive before the VMWI signal is applied (0 – 10.0s)	Time3	.5
VMWI Ring Policy	The parameter controls when a ring splash is played when a the VM server sends a SIP NOTIFY message to the PHONE ADAPTER indicating the status of the subscriber's mail box. 3 settings are available: New VM Available – ring as long as there is 1 or more unread voice mail New VM Becomes Available – ring when the number of unread voice mail changes from 0 to non-zero New VM Arrives – ring when the number of unread voice mail increases	Choice	New VM Available
Ring On No New VM	If enabled, the PHONE ADAPTER will play a ring splash when the VM server sends SIP NOTIFY message to the PHONE ADAPTER indicating that there are no more unread voice mails. Some equipment requires a short ring to precede the FSK signal to turn off VMWI lamp	Bool	No

Notes:

1. Caller number patterns are matched from Ring 1 to Ring 8. The first match (not the closest match) will be used for alerting the subscriber.

Parameter Name	Description	Type	Default
Ring1 Cadence	Cadence script for distinctive ring 1	CadScript	60(2/4)"
Ring2 Cadence	Cadence script for distinctive ring 2	CadScript	60(.3/.2, 1/.2,.3/4)"
Ring3 Cadence	Cadence script for distinctive ring 3	CadScript	60(.8/.4,.8/4)
Ring4 Cadence	Cadence script for distinctive ring 4	CadScript	60(.4/.2,.3/.2,.8/4)
Ring5 Cadence	Cadence script for distinctive ring 5	CadScript	60(.4/.2,.3/.2,.8/4)
Ring6 Cadence	Cadence script for distinctive ring 6	CadScript	60(.4/.2,.3/.2,.8/4)
Ring7 Cadence	Cadence script for distinctive ring 7	CadScript	60(.4/.2,.3/.2,.8/4)
Ring8 Cadence	Cadence script for distinctive ring 8	CadScript	60(.4/.2,.3/.2,.8/4)
CWT 1 Cadence	Cadence script for distinctive CWT (Call Waiting Tone) 1	CadScript	30(.3/9.7)
CWT2 Cadence	Cadence script for distinctive CWT 2	CadScript	30(.1/.1,.1/9.7)"
CWT3 Cadence	Cadence script for distinctive CWT 3	CadScript	30(.1/.1,.1/.1, .1/9.5)
CWT4 Cadence	Cadence script for distinctive CWT 4	CadScript	30(.1/.1,.3/.1, .1/9.3)
CWT5 Cadence	Cadence script for distinctive CWT 5	CadScript	30(.3/.1,.1/.1,.3/9. 1)
CWT6 Cadence	Cadence script for distinctive CWT 6	CadScript	30(.1/.1,.3/.1, .1/9.3)
CWT7 Cadence	Cadence script for distinctive CWT 7	CadScript	30(.1/.1,.3/.1, .1/9.3)

CWT8 Cadence	Cadence script for distinctive CWT 8	CadScript	2.3(..3/2)
Ring Waveform	Waveform for the ringing signal	{Sinusoid, Trapezoid}	Sinusoid
Ring Frequency	Frequency of the ringing signal. Valid values are 10 – 100 (Hz)	Uns8	25
Ring Voltage	Ringing voltage. 60-90 (V)	Uns8	70
CWT Frequency	Frequency script of the call waiting tone. All distinctive CWT is based on this tone.	FreqScript	440@-10

4.9.2. Progress Tones

Most of the 18 progress tones in the PHONE ADAPTER are played automatically in response to fixed stimuli. However, the administrator can select which SIP response codes correspond to the 4 SIT tones.

Response Status Code Handling			
SIT1 RSC ¹	SIP response status code to INVITE on which to play the SIT1 Tone	RscTmpl	
SIT2 RSC ¹	SIP response status code to INVITE on which to play the SIT2 Tone	RscTmpl	
SIT3 RSC ¹	SIP response status code to INVITE on which to play the SIT3 Tone	RscTmpl	
SIT4 RSC ¹	SIP response status code to INVITE on which to play the SIT4 Tone	RscTmpl	

The Frequencies of the actual progress tones are configurable to accommodate local and regional conventions.

Parameter Name	Description	Type	Default
Dial Tone ¹	Played when prompting the user to enter a phone number	ToneScript	350@-19,440@-19;10(*0/1+2)
Second Dial Tone	An alternative to <Dial Tone> when user tries to dial a 3-way call	ToneScript	420@-19,520@-19;10(*0/1+2)
Outside Dial Tone ¹	An alternative to <Dial Tone> usually used to prompt the user to enter an external phone number (versus an internal extension). This is triggered by a “,” character encountered in the dial plan.	ToneScript	420@-16;10(*0/1)
Prompt Tone ¹	Played when prompting the user to enter a call forward phone number	ToneScript	520@-19,620@-19;10(*0/1+2)
Busy Tone	Played when a 486 RSC is received for an outbound call	ToneScript	480@-19,620@-19;10(.5/.5/1+2)
Reorder Tone ^{1,2}	Played when an outbound call has failed or after the far end hangs up during an established call	ToneScript	480@-19,620@-19;10(.25/.25/1+2)
Off Hook Warning Tone ²	Played when the subscriber does not place the handset on the cradle properly	ToneScript	480@-10,620@0;10(.125/.125/1+2)
Ring Back Tone	Played for an outbound call when the far end is ringing	ToneScript	440@-19,480@-19;*(2/4/1+2)

Confirm Tone	This should be a brief tone to notify the user that the last input value has been accepted.	ToneScript	600@-16;1(.25/.25/1)"
SIT1 Tone	An alternative to <Reorder Tone> played when an error occurs while making an outbound call. The RSC to trigger this tone is configurable (see Section ???)	ToneScript	985@-16,1428@-16,1777@-16;20(.380/0/1,.380/0/2,.380/0/3,0/4/0)
SIT2 Tone	See <SIT1 Tone>	ToneScript	914@-16,1371@-16,1777@-16;20(.274/0/1,.274/0/2,.380/0/3,0/4/0)
SIT3 Tone	See <SIT1 Tone>	ToneScript	914@-16,1371@-16,1777@-16;20(.380/0/1,.380/0/2,.380/0/3,0/4/0)
SIT4 Tone	See <SIT 1 Tone>	ToneScript	985@-16,1371@-16,1777@-16;20(.380/0/1,.274/0/2,.380/0/3,0/4/0)
MWI Dial Tone ¹	This tone is played instead of <Dial Tone> when there are unheard messages in the subscriber's mail box	ToneScript	350@-19,440@-19;2(.1/.1/1+2);10(* /0/1+2)
Cfwd Dial Tone	Special dial tone played when call forward all is activated	ToneScript	350@-19,440@-19;2(.2/.2/1+2);10(* /0/1+2)
Holding Tone	Indicate to the local user that the far end has placed the call on hold	ToneScript	600@-16;*(.1/.1/1,.1/.1/1,.1/9.5/1)
Conference Tone	Plays to all parties when a 3-way conference is in progress	ToneScript	350@-16;30(.1/.1/1,.1/9.7/1)
Secure Call Indication Tone	This tone is played when a call is successfully switched to secure mode. It should be played only for a short while (< 30s) and at a reduced level (< -19 dBm) so that it will not interfere with the conversation.	ToneScript	397@-19,507@-19;15(0/2/0,.2/.1/1,.1/2.1/2)

Notes:

1. Reorder Tone is played automatically when <Dial Tone> or any of its alternatives times out
2. Off Hook Warning Tone (also called Howler Tone) is played when Reorder Tone times out

4.10. Less Frequently Used Parameters

4.10.1. Advanced Protocol Parameters

Parameter Name	Description	Type	Default
SIP Parameters			
Max Forward	SIP Max-Forward value. Range: 1 – 255	Uns8	70

Max Redirection	Number of times to allow an INVITE to be redirected by a 3xx response to avoid an infinite loop. Note: This parameter currently has no effect: there is no limit on number of redirection.	Uns8	5
Max Auth	Maximum number of times a request may be challenged (0-255)	Uns8	2
SIP User Agent Name	User-Agent Header to be used by the unit in outbound requests. If empty, the header is not included.	Str63	Linksys/ \$version
SIP Server Name	Server Header to used by the unit in responses to inbound responses. If empty, the header is not included.	Str63	Linksys/ \$version
SIP Accept Language	Accept-Language Header to be used by the unit. If empty, the header is not included.	Str31	
Remove Last Reg	Remove last registration before registering a new one if value is different one.	Bool	no
Use Compact Header	If set to yes, the PHONE ADAPTER will use compact SIP headers in outbound SIP messages. If set to no the PHONE ADAPTER will use normal SIP headers.	Bool	no
SIP Timer Values (sec)			
SIP T1	RFC 3261 T1 value (RTT Estimate). Range: 0 – 64 sec	Time3	.5
SIP T2	RFC 3261 T2 value (Maximum retransmit interval for non-INVITE requests and INVITE responses). Range: 0 – 64 sec	Time3	4
SIP T4	RFC 3261 T4 value (Maximum duration a message will remain in the network). Range: 0 – 64 sec	Time3	5
SIP Timer B	INVITE time out value. Range: 0 – 64 sec	Time3	32
SIP Timer F	Non-INVITE time out value. Range: 0 – 64 sec	Time3	32
SIP Timer H	INVITE final response time out value. Range: 0 – 64 sec	Time3	32
SIP Timer D	ACK hang around time. Range: 0 – 64 sec	Time3	32
SIP Timer J	Non-INVITE response hang around time. Range: 0 – 64 sec	Time3	32
INVITE Expires	INVITE request Expires header value in sec. 0 = do not include Expires header in INVITE. Range: 0 – (2 ³¹ – 1)	Time0	180
ReINVITE Expires	ReINVITE request Expires header value in sec. 0 = do not include Expires header in the request. Range: 0 – (2 ³¹ – 1)	Time0	30
Reg Min Expires	Minimum registration expiration time allowed from the proxy in the Expires header or as a Contact header parameter. If proxy returns something less this value, then the minimum value is used.	Time0	1
Reg Max Expires	Maximum registration expiration time allowed from the proxy in the Min-Expires header. If	Time0	7200

	value is larger than this, then the maximum value is used		
Reg Retry Intvl	Interval to wait before the PHONE ADAPTER retries registration again after encountering a failure condition during last registration	Time0	30
Reg Retry Long Interval	When Registration fails with a SIP response code that does no match <Retry Reg RSC>, the PHONE ADAPTER will wait for the delay specified in this parameter before retrying. If this parameter is 0, the PHONE ADAPTER will stop retrying. This value should be much larger than <Reg Retry Intvl> which should not be 0.	Time0	1200
Response Status Code Handling			
SIT1 RSC ¹	SIP response status code to INVITE on which to play the SIT1 Tone	RscTmpl	
SIT2 RSC ¹	SIP response status code to INVITE on which to play the SIT2 Tone	RscTmpl	
SIT3 RSC ¹	SIP response status code to INVITE on which to play the SIT3 Tone	RscTmpl	
SIT4 RSC ¹	SIP response status code to INVITE on which to play the SIT4 Tone	RscTmpl	
Try Backup RSC	SIP response status code on which to retry a backup server for the current request	RscTmpl	
Retry Reg RSC	Interval to wait before the PHONE ADAPTER retries registration again after encountering a failure condition during last registration	Time0	30
RTP Parameters			
RTP Port Min ²	Minimum port number for RTP transmission and reception	Port	16384
RTP Port Max ²	Maximum port number for RTP transmission and reception	Port	16482
RTP Packet Size	Packet size in sec. Valid values must be multiple of 0.01s. Range: 0.01 – 0.16	Time3	0.02
RTCP Tx Interval ⁴	Controls the interval (sec) to send out RTCP sender report on an active connection. Range: 0 – 255 (s)	Time0	0

Notes:

1. Reorder or Busy Tone will be played by default for all unsuccessful response status code
2. <RTP Port Min> and <RTP Port Max> should define a range that contains at least 4 even number ports, such as 100 – 106
3. If inbound SIP requests contain compact headers, PHONE ADAPTER will reuse the same compact headers when generating the response regardless the settings of the <Use Compact Header> parameter. If inbound SIP requests contain normal headers, PHONE ADAPTER will substitute those headers with compact headers (if defined by RFC 261) if <Use Compact Header> parameter is set to “yes.”
4. During an active connection, the PHONE ADAPTER can be programmed to send out compound RTCP packet on the connection. Each compound RTP packet except the last one contains a SR (Sender Report) and a SDES.(Source Description). The last RTCP packet contains an additional BYE packet. Each SR except the last one contains exactly 1 RR (Receiver Report); the last SR

carries no RR. The SDES contains CNAME, NAME, and TOOL identifiers. The CNAME is set to <User ID>@<Proxy>, NAME is set to <Display Name> (or “Anonymous” if user blocks caller ID), and TOOL is set to the Vendor/Hardware-platform-software-version (such as Linksys/PHONE ADAPTER2000-1.0.31(b)). The NTP timestamp used in the SR is a snapshot of the PHONE ADAPTER’s local time, not the time reported by an NTP server. If the PHONE ADAPTER receives a RR from the peer, it will attempt to compute the round trip delay and show it as the <Call Round Trip Delay> value (ms) in the Info section of PHONE ADAPTER web page.

4.10.2. Additional User Account Information

Parameter Name	Description	Type	Default
Line Enable	Enable this line for service	Bool	Yes
MOH Server ²	The User ID or URL of the auto-answering SAS to contact for MOH services. Examples: 5000, 1001@music.Linksys.com, 66.12.123.15:5061. Note: When only a user-id is given, the current proxy or outbound proxy will be contacted as in the making of a regular outbound call. MOH is disabled if this parameter is not specified (empty).	Str127	Empty
SIP Port	SIP message listening port and transmission port	Port	5060
SIP TOS/DiffServ Value	TOS/DiffServ field value in UDP IP Packets carrying a SIP Message	Byte	0x68
RTP TOS/DiffServ Value	TOS/DiffServ field value in UDP IP Packets carrying a RTP data	Byte	0xb8
SAS Enable ³	Enables the FXS Line to act as a Streaming Audio Source (SAS). If enabled, the line cannot be used for making outgoing calls. Instead, it auto-answers incoming calls and streams audio RTP packets to the calling party.	Bool	No
SAS DLG Refresh Intvl ³	If non-zero, this is the interval at which SAS sends out session refresh (SIP re-INVITE) messages to detect if connection to the caller is still up. If the caller does not respond to refresh message, PHONE ADAPTER will terminate this call with a SIP BYE message. The default = 0 (Session refresh disabled) Range = 0-255 (s)		0
SAS Inbound RTP Sink ³	The purpose of this parameter is to work around devices that do not play inbound RTP if the SAS line declares itself as a “sendonly” device and tells the client not to stream out audio. This parameter is a FQDN or IP address of a RTP sink to be used by the PHONE ADAPTER SAS line in the SDP of its 200 response to inbound INVITE from a client. It will appear in the c = line and the port number and, if specified, in the m = line of the SDP. If this value is not specified or equal to 0, then c = 0.0.0.0 and a=sendonly will be used in the SDP to tell the SAS client to not to send any RTP to this SAS line. If a non-zero value is specified, then a=sendrecv and the SAS client will stream audio to the given address. Special case: If the value is \$IP, then the	Str63	

	SAS line's own IP address is used in the c = line and a=sendrecv. In that case the SAS client will stream RTP packets to the SAS line. The default value is [empty].		
SIP Debug Option	None, 1-line, full, exclude OPTIONS, exclude REGISTER, exclude NOTIFY, ...	Choice	none
Network Jitter Level	4 settings are available: very high, high, medium, low. This parameter affects how jitter buffer size is adjusted in the PHONE ADAPTER. Jitter buffer size is adjusted dynamically. The minimum jitter buffer size is 30 ms or (10 ms + current RTP frame size), which ever is larger, for all jitter level settings. But the starting jitter buffer size value is larger for higher jitter levels. This parameter controls the rate at which to adjust the jitter buffer size to reach the minimum. If the jitter level is set to high, then the rate of buffer size decrement is slower (more conservative), else faster (more aggressive).	Choice	High
SIP 100REL Enable	Enable the support or the 100rel SIP extension for reliable transmission of provisional responses (18x) and the use of PRACK requests.	Bool	No
Blind Attn-Xfer Enable	If enabled, the PHONE ADAPTER performs an attended transfer operation by terminating the current call leg, and blind transferring the other call leg. If disabled, the PHONE ADAPTER performs an attended transfer by referring the other call leg to the current call leg while maintaining both call legs.	Bool	No

Notes:

1. If proxy responded to REGISTER with a smaller Expires value, the PHONE ADAPTER will renew registration based on this smaller value instead of the configured value. If registration failed with an "Expires too brief" error response, the PHONE ADAPTER will retry with the value given in the Min-Expires header in the error response.

2. MOH Notes:

- The remote party must indicate that it can receive audio while holding MOH to work. That is the SIP 2xx response from the remote party in reply to the re-INVITE from the PHONE ADAPTER to put the call on hold must have the SDP indicate a sendrecv or recvonly attribute and the remote destination address and port must not be 0

3. SAS Notes:

- Either or both of lines 1 and 2 can be configured as an SAS server.
- Each server can maintain up to 5 simultaneous calls. If the second line on the PHONE ADAPTER is disabled, then the SAS line can maintain up to 10 simultaneous calls. Further incoming calls will receive a busy signal (SIP 486 Response).
- The streaming audio source must be off-hook for the streaming to occur. Otherwise incoming calls will get a error response (SIP 503 Response). The SAS line will not ring for incoming calls even if the attached equipment is on-hook
- If no calls are in session, battery is removed from tip-and-ring of the FXS port. Some audio source devices have an LED to indicate the battery status. This can be used as a visual indication whether any audio streaming is in progress.

- IVR can still be used on an SAS line, but the user needs to follow some simple steps: a) Connect a phone to the port and make sure the phone is on-hook, b) power on the PHONE ADAPTER and c) pick up handset and press * * * * to invoke IVR in the usual way. The idea behind this is that if the PHONE ADAPTER boots up and finds that the SAS line is on-hook, it will not remove battery from the line so that IVR may be used. But if the PHONE ADAPTER boots up and finds that the SAS line is off-hook, it will remove battery from the line since no audio session is in progress.
- Set up the Proxy and Subscriber Information for the SAS Line as you normally would with a regular user account.
- Call Forwarding, Call Screening, Call Blocking, DND, and Caller-ID Delivery features are not available on an SAS line.

4.10.3. Per-Line Polarity Settings

Parameter Name	Description	Type	Default
Idle Polarity	Polarity before call connected	{Forward,Reverse}	Forward
Caller Conn Polarity	Polarity after outbound call connected	{Forward,Reverse}	Reverse
Callee Conn Polarity	Polarity after inbound call connected	{Forward,Reverse}	Reverse

4.10.4. Additional Timer Values (sec)

Parameter Name	Description	Type	Default
Hook Flash Timer Min	Minimum on-hook time before off-hook to qualify as hook-flash. Less than this the on-hook event is ignored. Range: 0.1 – 0.4 sec	Time3	0.1
Hook Flash Timer Max	Maximum on-hook time before off-hook to qualify as hook-flash. More than this the on-hook event is treated as on-hook (no hook-flash event). Range: 0.4 – 1.6 sec	Time3	0.9
Callee On Hook Delay	The phone must be on-hook for at this time in sec before the PHONE ADAPTER will tear down the current inbound call. It does not apply to outbound calls. Range: 0 – 255 sec	Time0	0
Reorder Delay	Delay after far end hangs up before reorder tone is played. 0 = plays immediately, inf = never plays. Range: 0 – 255 sec	Time0	5
Call Back Expires	Expiration time in sec of a call back activation. Range: 0 – 65535 sec	Time0	1800
Call Back Retry Intvl	Call back retry interval in sec. Range: 0 – 255 sec	Time0	30
Call Back Delay	Delay after receiving the first SIP 18x response before declaring the remote end is ringing. If a busy response is received during this time, the PHONE ADAPTER still considers the call as failed and keeps on retrying.	Time3	0.5
VMWI Refresh Intvl	Interval between VMWI refresh to the CPE	Time3	0.5
Interdigit Long Timer ²	Long timeout between entering digits when dialing. Range: 0 – 64 sec	Time0	10
Interdigit Short Timer ²	Short timeout between entering digits when dialing. Range: 0 – 64 sec	Time0	3

CPC Delay ^{3,4}	Delay in seconds after caller hangs up when the PHONE ADAPTER will start removing the tip-and-ring voltage to the attached equipment of the called party. Range= 0 to 255(s) Resolution = 1 (s)		2
CPC Duration ^{3,4}	Duration in seconds for which the tip-to-ring voltage is removed after the caller hangs up. After that tip-to-ring voltage is restored and dial tone will apply if the attached equipment is still off hook. CPC is disabled if this value is set to 0. Range= 0 to 1.000 (s) Resolution = 0.001 (s)		0 (CPC disabled)

Notes:

1. The Call Progress Tones and DTMF playback level are not affected by the <FXS Port Output Gain>.
2. The interdigit timer values are used as defaults when dialing. The Interdigit_Long_Timer is used after any one digit, if all valid matching sequences in the dial plan are incomplete as dialed. The Interdigit_Short_Timer is used after any one digit, if at least one matching sequence is complete as dialed, but more dialed digits would match other as yet incomplete sequences.
3. PHONE ADAPTER has had polarity reversal feature since release 1.0 which can be applied to both the caller and the callee end. This feature is generally used for answer supervision on the caller side to signal to the attached equipment when the call has been connected (remote end has answered) or disconnected (remote end has hung up). This feature should be disabled for the called party (ie by using the same polarity for connected and idle state) and the CPC feature should be used instead.
4. Without CPC enabled, reorder tone will be played after a configurable delay. If CPC is enabled, dial tone will be played when tip-to-ring voltage is restored.

4.10.5. Miscellaneous Parameters

Parameter Name	Description	Type	Default
Set Local Date (mm/dd/yyyy)	Setting the local date; year is optional and can be 2-digit or 4-digit	Str10	
Local Time (HH/mm/ss)	Setting the local time; second is optional.	Str8	
Time Zone	Number of hours to add to GMT to form local time for caller-id generation. Choices: GMT-12:00, GMT-11:00,..., GMT, GMT+01:00, GMT+02:00, ..., GMT+13:00	Choice	GMT-07:00
FXS Port Impedance	Electrical impedance of the FXS port.	{600, 900, 600+2.16uF, 900+2.16uF, 270+750 150nF, 220+820 120nF, 220+820 115nF, 370+620 310nF}	600
FXS Port Input Gain	Input Gain in dB. Valid values are 6.0 to –infinity. Up to 3 decimal places	dB	-3
FXS Port Output Gain	Similar to <FXS Port Input Gain> but apply to the output signal	dB	-3

DTMF Playback Level	Local DTMF playback level in dBm (up to 1 decimal place)	PwrLevel	-10.0
DTMF Playback Length	Local DTMF playback duration in ms	Time3	.1
Detect ABCD	Enable local detection of DTMF ABCD	Bool	Yes
Playback ABCD	Enable local playback of OOB DTMF ABCD	Bool	Yes
Caller ID Method	The following choices are available: <ul style="list-style-type: none"> • Bellcore (N.Amer,China): CID, CIDCW, and VMWI. FSK sent after 1st ring (same as ETSI FSK sent after 1st ring) (no polarity reversal or DTAS) • DTMF (Finland,Sweden): CID only. DTMF sent after polarity reversal (and no DTAS) and before 1st ring • DTMF (Denmark): CID only. DTMF sent after polarity reversal (and no DTAS) and before 1st ring • ETSI DTMF: CID only. DTMF sent after DTAS (and no polarity reversal) and before 1st ring • ETSI DTMF With PR: CID only. DTMF sent after polarity reversal and DTAS and before 1st ring • ETSI DTMF After Ring: CID only. DTMF sent after 1st ring (no polarity reversal or DTAS) • ETSI FSK: CID, CIDCW, and VMWI. FSK sent after DTAS (but no polarity reversal) and before 1st ring. Will wait for ACK from CPE after DTAS for CIDCW. • ETSI FSK With PR (UK): CID, CIDCW, and VMWI. FSK is sent after polarity reversal and DTAS and before 1st ring. Will wait for ACK from CPE after DTAS for CIDCW. Polarity reversal is applied only if equipment is on hook. 	Choice	Bellcore
FXS Port Power Limit	Options: 1, 2, 3, 4, 5, 6, 7, 8	Choice	3

Notes:

1. It should be noted that the choice of CID method will affect the following features:
 - On Hook Caller ID Associated with Ringing – This type of Caller ID is used for incoming calls when the attached phone is on hook. See figure below (a) – (c). All CID methods can be applied for this type of caller-id
 - On Hook Caller ID Not Associated with Ringing – This feature is used for send VMWI signal to the phone to turn the message waiting light on and off (see Figure 1 (d) and (e)). This is available only for FSK-based caller-id methods: “Bellcore”, “ETSI FSK”, and “ETSI FSK With PR”
 - Off Hook Caller ID – This is used to delivery caller-id on incoming calls when the attached phone is off hook. See figure below (f). This can be call waiting caller ID (CIDCW) or to notify the user that the far end party identity has changed or updated (such as due to a call transfer). This is only available if the caller-id method is one of “Bellcore”, “ETSI FSK”, or “ETSI FSK With PR”.

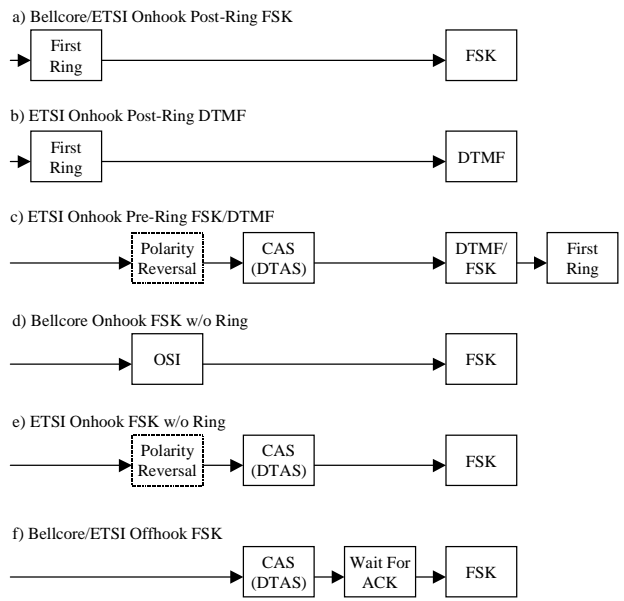

Figure: PHONE ADAPTER Caller ID Delivery Architecture

5. Expected Feature Behavior

The PHONE ADAPTER can be configured to the custom requirements of the service provider, so that from the subscriber's point of view, the service behaves exactly as the service provider wishes – with varying degrees of control left with the end user. This means that a service provider can leverage the programmability of the PHONE ADAPTER to offer sometimes subtle yet continually valuable and differentiated services optimized for the network environment or target market(s).

This section of the Administration Guide, describes how some of the supported basic and enhanced, or supplementary services could be implemented. The implementations described below by no means are the only way to achieve the desired service behavior.

To understand the specific implementation options of the below features, including parameters, requirements and contingencies please refer the section Configuration Parameters, section **Error! Reference source not found.**

5.1. Originating a Phone Call

Service Description	Placing telephone a call to another telephone or telephony system (IVR, conference bridge, etc.). This is the most basic service.
User Action Required to Activate or Use	When the user picks up the handset, the PHONE ADAPTER provides dial tone and is ready to collect dialing information via DTMF digits from the telephone Touchtone key pad.
Expected Call and Network Behavior	While it is possible to support overlapped dialing within the context of SIP, the PHONE ADAPTER collects a complete phone number and sends the full number in a SIP INVITE message to the proxy server for further call processing. In order to minimize dialing delay, the PHONE ADAPTER maintains a dial plan and matches it against the cumulative number entered by the user. The PHONE ADAPTER also detects invalid phone numbers not compatible with the dial plan and alerts the user via a configurable tone (Reorder) or announcement.
User Action Required to Deactivate or End	Hang-up the telephone.

5.2. Receiving a Phone Call

Service Description	The PHONE ADAPTER can receive calls from the PSTN or other IP Telephony subscribers
User Action Required to Activate or Use	When the telephone rings, pick up the handset and begin talking.
Expected Call and Network Behavior	Each subscriber is assigned an E.164 ID (phone number) so that they may be reached

	from wired or wireless callers on the PSTN or IP network. The PHONE ADAPTER supplies ring voltage to the attached telephone set to alert the user of incoming calls.
User Action Required to Deactivate or End	Hang-up the telephone.

5.3. Caller ID

Service Description	If available, the PHONE ADAPTER supports the generation and pass through of Caller ID information.
User Action Required to Activate or Use	No user action required. The user's telephone equipment must support Caller ID to display the caller's name and/or number.
Expected Call and Network Behavior	In between ringing bursts, the PHONE ADAPTER can generate a Caller-ID signal to the attached phone when the phone is on-hook. As part of the INVITE message, the PHONE ADAPTER sends the caller's name and number as it is configured in the profile.
User Action Required to Deactivate or End	No user action required. See CLIP and CLIR.

5.4. Calling Line Identification Presentation (CLIP)

Service Description	Some users will elect to block their Caller ID information for all outgoing calls. However, there may be circumstances where sending Caller ID information for a call is desired, i.e. trying to reach a party that does not accept Caller ID blocked calls.
User Action Required to Activate or Use	Lift the receiver Listen for dial tone Press * __ Listen for dial tone Dial the telephone number you are calling
Expected Call and Network Behavior	Caller ID will be sent to the distant party for this call only. Users must repeat this process at the start of each call.
User Action Required to Deactivate or End	No action required. This service is only in

	effect for the duration of the current call.
--	--

5.5. Calling Line Identification Restriction (CLIR) – Caller ID Blocking

Service Description	This feature allows the user to block the delivery of their Caller ID to the number they are calling. This feature must be activated prior to dialing each call and is only in effect for the duration of each call.
User Action Required to Activate or Use	Lift the receiver Listen for dial tone Press * __ Listen for dial tone Dial the telephone number you are calling You must repeat this process at the start of each call
Expected Call and Network Behavior	The user activates this service to hide his Caller ID when making an outgoing call.
User Action Required to Deactivate or End	No action required. This service is only in effect for the duration of the current call.

5.6. Call Waiting

Service Description	The user can accept a call from a 3rd party while engaging in an active call. The PHONE ADAPTER shall alert the subscriber of the 2nd incoming call by playing a call waiting tone.
User Action Required to Activate or Use	If the you choose to answer the second call either: Press and release your phone's switch hook (the button you release when you take your phone off the hook) or Press the flash button (if your phone has one). This puts your first call on hold and automatically connects you to your second call. To put your second caller back on hold and return to your first caller, press the switch hook or flash button again. (You can alternate between calls as often as you like.)
Expected Call and Network Behavior	If the user is on a call when another call comes in they will hear a series of beeps / tones

	alerting them to the second call. The person calling will hear normal ringing.
User Action Required to Deactivate or End	See Cancel Call Waiting.

5.7. Disable or Cancel Call Waiting

Service Description	The PHONE ADAPTER supports disabling of call waiting permanently or on a per call basis.
User Action Required to Activate or Use	<p>To temporarily disable Call Waiting (for the length of one call):</p> <p>Before placing a call:</p> <p>Lift Receiver</p> <p>Press * __</p> <p>Listen for dial tone then dial the number you want to call.</p> <p>Call Waiting is now disabled for the duration of this call only.</p> <p>To deactivate Call Waiting while on a call:</p> <p>Press the switch hook or flash button briefly. This puts the first call on hold.</p> <p>Listen for three short tones and then a dial tone.</p> <p>Press * __</p> <p>Listen for dial tone then return to your call by pressing the switch hook or flash button. Call Waiting is now disabled for the duration of this call.</p> <p>To deactivate Call Waiting while on a permanent basis (until cancelled):</p> <p>Lift the receiver</p> <p>Listen for dial tone</p> <p>Press * __</p> <p>You will hear a confirmation tone signaling your request to cancel Call Waiting has been accepted.</p>
Expected Call and Network Behavior	Callers who dial your number will receive a busy signal or, if available, the caller will be forwarded to voice mail or another predetermined forwarding number.
User Action Required to Deactivate or End	If you have cancelled Call Waiting temporarily,

	<p>no user action is required.</p> <p>If you deactivated call waiting and wish to reinstate the service, do the following:</p> <p>Lift the receiver</p> <p>Listen for dial tone</p> <p>Press * __</p> <p>You will hear a confirmation tone signaling your request to cancel Call Waiting has been accepted.</p>
--	---

5.8. Call-Waiting with Caller ID

Service Description	When the user is on the phone and has Call Waiting active, the new caller's Caller ID information will be displayed on the users phone display screen at the same time the user is hearing the Call Waiting beeps / tones.
User Action Required to Activate or Use	The telephone equipment connected to the PHONE ADAPTER must support Call-Waiting with Caller ID.
Expected Call and Network Behavior	In between call waiting tone bursts, the PHONE ADAPTER can generate a Caller-ID signal to the attached phone when it is off hook.
User Action Required to Deactivate or End	Not applicable.

5.9. Voice Mail

Service Description	Service Providers may provide voice mail service to their subscribers. Users have the ability to retrieve voice mail via the telephone connected to the PHONE ADAPTER.
User Action Required to Activate or Use	<p>The PHONE ADAPTER indicates that a message is waiting by, playing stuttered dial tone when the user picks up the handset.</p> <p>To retrieve messages:</p> <p>Lift the receiver</p> <p>Listen for dial tone</p> <p>Dial the phone number assigned to the PHONE ADAPTER</p> <p>You will be connected to the voice mail server and prompted by a voice response system with</p>

	instructions to listen to your messages.
Expected Call and Network Behavior	When voice mail is available for a subscriber, a notification message will be sent from the Voice Mail server to the PHONE ADAPTER. When the user dials their own phone number, the PHONE ADAPTER connects the subscriber their voice mail system which can then connect them to their individual voice mail box.
User Action Required to Deactivate or End	Follow instructions of the voice mail system or simply hang-up the telephone.

5.10. Attendant Call Transfer

Service Description	Attendant Call Transfer lets a customer use their Touchtone phone to send a call to any other phone, inside or outside their business, including a wireless phones.
User Action Required to Activate or Use	<p>While in a call with the party to be transferred:</p> <p>Press the switch hook or flash button on the phone to place the party on hold</p> <p>Listen for three short tones followed by dial tone</p> <p>Dial the number to which you will transfer the caller</p> <p>Stay on the line until the called number answers</p> <p>Announce the call</p> <p>Press the switch hook or flash button adding the held party to the call</p> <p>Hang up to connect the two parties and transfer the call</p> <p>Note: You can hook flash while the 3rd party is ringing to start an early conference. Then hang up to complete the transfer without waiting for the 3rd party to answer first.</p>
Expected Call and Network Behavior	When the user presses the switch hook or flash button, the transferee is placed on hold. When the user successfully dials the transfer number and the party answers the transferee can be added to the call by pressing the switch hook or flash button creating a three-way conference. When the user hangs up the phone the transferee and the called party

	remain in a call.
User Action Required to Deactivate or End	Not applicable.

5.11. Unattended or “Blind” Call Transfer

Service Description	Unattended or “Blind” Call Transfer lets a customer use their Touchtone phone to send a call to any other phone, inside or outside their business, including a wireless phones.
User Action Required to Activate or Use	While in a call with the party to be transferred: Press the switch hook or flash button on the phone to place the party on hold Enter * __ Dial the number to which you will transfer the caller The call is transferred when a complete number is entered. You will hear a short confirmation tone, followed by regular dial tone
Expected Call and Network Behavior	When the user presses the switch hook or flash button, the transferee is placed on hold. When the user successfully dials the transfer number, the transferee will automatically call the dialed number.
User Action Required to Deactivate or End	No applicable.

5.12. Call Hold

Service Description	Call Hold lets you put a caller on hold for an unlimited period of time. It is especially useful on phones without the hold button. Unlike a hold button, this feature provides access to a dial tone while the call is being held.
User Action Required to Activate or Use	Press the switch hook or flash button on the phone to place the first party on hold. You will hear a dial tone. To make another call: Enter the new number To return to call on hold: Hang up and the phone set will ring with the first call on the line (or Hook Flash again)

Expected Call and Network Behavior	
User Action Required to Deactivate or End	Hang-up the telephone.

5.13. Three-Way Calling

Service Description	The user can originate a call to a 3rd party while engaging in an active call.
User Action Required to Activate or Use	<p>Press the switch hook or flash button on the phone to place the first party on hold</p> <p>Listen for three short tones followed by dial tone</p> <p>Dial the number of the 3rd party.</p> <p>When the 3rd party answers you may have a conversation with them while the other party is on hold.</p> <p>To hold a conference with the party on hold and the 3rd party, simply press the switch hook or flash button</p>
Expected Call and Network Behavior	The PHONE ADAPTER supports up to two calls per line. The PHONE ADAPTER can conference two calls by bridging the 2 nd and 3 rd parties.
User Action Required to Deactivate or End	Hang-up the telephone.

5.14. Three-Way Ad-Hoc Conference Calling

Service Description	This feature allows the user to conference up to two other numbers on the same line to create a three-way call.
User Action Required to Activate or Use	<p>If you are already on a call and wish to add a third party:</p> <p>Press the switch hook or flash button</p> <p>Listen for dial tone</p> <p>Dial the third party normally</p> <p>When the third party number starts to ring press the switch hook or flash button again</p> <p>You now have the original caller and the third party together with you on the same call.</p> <p>If you want to initiate a new Three Way Call:</p>

	Call the first party in the normal manner Follow the directions for adding a third party (see instructions above)
Expected Call and Network Behavior	The PHONE ADAPTER can host a 3-way conference and perform 3-way audio mixing (without the need of an external conference bridge device or service). If you also have Call Transfer you can also hang up at any time to transfer the original caller to the third party
User Action Required to Deactivate or End	

5.15. Call Return

Service Description	The PHONE ADAPTER supports a service that allows the PHONE ADAPTER to automatically dial the last caller's number.
User Action Required to Activate or Use	Pick up the receiver Listen for dial tone Press *__ to dial back the last caller that tried to reach you.
Expected Call and Network Behavior	This service gives the user the convenience of recalling the last incoming call to their number automatically.
User Action Required to Deactivate or End	No user action required

5.16. Automatic Call Back

Service Description	This feature allows the user to place a call to the last number they tried to reach whether the call was answered, unanswered or busy by dialing an activation code.
User Action Required to Activate or Use	Pick up the receiver Listen for dial tone Press *__
Expected Call and Network Behavior	If the number called is idle the call will ring through and complete normally. If the called number is busy the user will hear a special announcement and the feature will monitor the called number for up to 30 minutes. When both

	<p>lines are idle, the user hears a special ring.</p> <p>During the monitoring process the user can continue to originate and receive calls without affecting the Call Return on Busy request. Call Return on Busy requests can be canceled by dialing the deactivation code.</p>
User Action Required to Deactivate or End	<p>Lift the receiver</p> <p>Listen for dial tone</p> <p>Press * __</p>

5.17. Call FWD – Unconditional

Service Description	<p>All calls are immediately forwarded to the designated forwarding number. The PHONE ADAPTER will not ring or provide call waiting when Call FWD – Unconditional is activated.</p>
User Action Required to Activate or Use	<p>Lift the receiver</p> <p>Listen for dial tone</p> <p>Press * __</p> <p>Listen for dial tone and enter the telephone number you are forwarding your call to.</p> <p>Activation will be confirmed with three short bursts of tone and your forwarding will be activated.</p> <p>Alternatively, the user can activate this feature from a web browser interface.</p>
Expected Call and Network Behavior	<p>This feature allows a user the option to divert (forward) all calls to their telephone number to any number using the touchtone keypad of their telephone or web browser interface. This service is activated or deactivated from the phone being forwarded or the web browser interface.</p>
User Action Required to Deactivate or End	<p>Lift the receiver</p> <p>Listen for dial tone</p> <p>Press * __</p> <p>You will hear a confirmation tone signaling your change has been accepted.</p> <p>Alternatively, the user can deactivate this feature from a web browser interface.</p>

5.18. Call FWD – Busy

Service Description	Calls are forwarded to the designated forwarding number if the subscriber's line is busy because of the following; Primary line already in a call, primary and secondary line in a call or conference.
User Action Required to Activate or Use	<p>Lift the receiver</p> <p>Listen for dial tone</p> <p>Press * __</p> <p>Listen for dial tone and enter the telephone number you are forwarding your call to.</p> <p>Activation will be confirmed with three short bursts of tone and your forwarding will be activated.</p> <p>Alternatively, the user can activate this feature from a web browser interface.</p>
Expected Call and Network Behavior	This feature allows a user the option to divert (forward) calls to their telephone number to any number when their phone is busy or in conference by using the touchtone keypad of their telephone or web browser interface. This service is activated or deactivated from the phone being forwarded or the web browser interface.
User Action Required to Deactivate or End	<p>Lift the receiver</p> <p>Listen for dial tone</p> <p>Press * __</p> <p>You will hear a confirmation tone signaling your change has been accepted.</p> <p>Alternatively, the user can deactivate this feature from a web browser interface.</p>

5.19. Call FWD - No Answer

Service Description	Calls are forwarded to the designated forwarding number after a configurable time period elapses while the PHONE ADAPTER is ringing and does not answer.
User Action Required to Activate or Use	<p>Lift the receiver</p> <p>Listen for dial tone</p> <p>Press * __</p>

	<p>Listen for dial tone and enter the telephone number you are forwarding your call to.</p> <p>Activation will be confirmed with three short bursts of tone and your forwarding will be activated.</p> <p>Alternatively, the user can activate this feature from a web browser interface.</p> <p>Note: The forward delay is entered from the web interface. Default is 20s</p>
Expected Call and Network Behavior	<p>This feature allows a user the option to divert (forward) calls to their telephone number to any other dialable number when their phone is not answered by using the touchtone keypad of their telephone or web browser interface. This service is activated or deactivated from the phone being forwarded or the web browser interface.</p>
User Action Required to Deactivate or End	<p>Lift the receiver</p> <p>Listen for dial tone</p> <p>Press * __</p> <p>You will hear a confirmation tone signaling your change has been accepted.</p> <p>Alternatively, the user can deactivate this feature from a web browser interface.</p>

5.20. Anonymous Call Blocking

Service Description	<p>By setting the corresponding configuration parameter on the PHONE ADAPTER, the subscriber has the option to block incoming calls that do not reveal the caller's Caller ID.</p>
User Action Required to Activate or Use	<p>Pick up the receiver</p> <p>Listen for dial tone</p> <p>To Activate Press * __</p>
Expected Call and Network Behavior	<p>When activated by the user, callers will hear (busy) tone.</p>
User Action Required to Deactivate or End	<p>To De-activate Press * __</p>

5.21. Distinctive / Priority Ringing and Call Waiting Tone

Service Description	<p>The PHONE ADAPTER supports a number of</p>
---------------------	---

	ringing and call waiting tone patterns to be played when incoming calls arrive. The choice of alerting pattern to use is carried in the incoming SIP INVITE message inserted by the SIP Proxy Server (or other intermediate application server in the Service Provider's domain).
User Action Required to Activate or Use	Pick up the receiver Listen for dial tone Press * __
Expected Call and Network Behavior	With this service, incoming calls from up to __ telephone numbers can be automatically identified by distinctive ringing. A distinctive ringing pattern (i.e. short-long-short) accompanies incoming calls from the designated telephone numbers. If the user is engaged in conversation and a call from one of the designated numbers arrives, a distinctive call waiting tone (i.e. short-long-short) accompanies the incoming call. Calls from other telephone numbers ring normally.
User Action Required to Deactivate or End	

5.22. Speed Calling – Up to Eight (8) Numbers or IP Addresses

Service Description	The PHONE ADAPTER supports user programming of up to 8 long distance, local, international or emergency numbers and/or IP addresses for fast and easy access.
User Action Required to Activate or Use	Pick up the receiver Listen for dial tone Press * __ Dial the single digit code under which the number is to be stored (2-9) Dial the complete number to be stored just as if you were going to dial it yourself Listen for Confirmation tone (two short beeps) Hang up or repeat the sequence Note: To enter IP addresses, a graphical user interface like a web browser must be used.

Expected Call and Network Behavior	Pick up the receiver Listen for dial tone Press single digit code assigned to the stored number (2-9) Press # to signal dialing complete The number is automatically dialed normally.
User Action Required to Deactivate or End	None

6. Troubleshooting

6.1. Call Statistics Reporting

The following lists the statistics collected by the PHONE ADAPTER during normal operation. These statistics are presented in the PHONE ADAPTER web-page (under the "Info" tab). Line status is reported for each line (1 and 2). Each line maintains up to 2 calls: Call 1 and 2.

System Status	
Current Time	Current time and date. E.g., 10/3/2003 16:43:00
Elapsed Time	Total time elapsed since last reboot. E.g., 25 days and 18:12:36
Broadcast Pkts Sent	Total number of broadcast packets sent
Broadcast Pkts Recv	Total number of broadcast packets received
Broadcast Bytes Sent	Total number of broadcast bytes sent
Broadcast Bytes Recv	Total number of broadcast bytes received and processed
Broadcast Packets Dropped	Total number of broadcast packets received but not processed
Broadcast Bytes Dropped	Total number of broadcast bytes received but not processed
RTP Packets Sent	Total number of RTP packets sent (including redundant packets)
RTP Packets Received	Total number of RTP packets received (including redundant packets)
RTP Bytes Sent	Total number of RTP bytes sent
RTP Bytes Received	Total number of RTP bytes received
SIP Messages Sent	Total number of SIP messages sent (including retransmissions)
SIP Messages Received	Total number of SIP messages received (including retransmissions)
SIP Bytes Sent	Total number of bytes of SIP messages sent (including retransmissions)
SIP Bytes Received	Total number of bytes of SIP messages received (including retransmissions)
External IP	External IP address used for NAT mapping
Line 1/2 Status	
Hook State	State of the hook switch: On or Off
Registration State	Registration state of the line: Not Registered, Registered or Failed
Last Registration At	Local time of the last successful registration
Next Registration In	Number of seconds before the next registration renewal
Message Waiting	Indicate whether new voice mails available: Yes or No
Call Back Active	Indicate whether a call back request is in progress: Yes or No
Last Called Number	The last number called
Last Caller Number	The number of the last caller
Mapped SIP Port	NAT Mapped SIP Port
Call 1/2 Status	
State	State of the call: Idle, Dialing, Calling, Proceeding, Ringing, Answering, Connected, Hold, Holding, Resuming, or Reorder
Tone	Tone playing for this call: Dial, 2 nd Dial, Outside Dial, Ring Back, Ring, Busy, Reorder, SIT1- 4, Call Waiting, Call Forward, Conference,

	Prompt, Confirmation, or Message-Waiting
Encoder	Encoder in use: G711u, G711a, G726-16/24/32/40, G729a, or G729ab
Decoder	Decoder in use: G711u, G711a, G726-16/24/32/40, G729a, or G729ab
FAX	Indicate whether FAX pass-through mode has been initiated: Yes or No
Type	Indicate the call type: Inbound or Outbound
Remote Hold	Indicate whether the remote end has placed the call on hold: Yes or No
Call Back	Indicate whether the call is triggered by a call back request: Yes or No
Peer Name	Name of the peer
Peer Phone	Phone number of the peer
Duration	Duration of the call in hr/min/sec format
Packets Sent	Number of RTP packets sent
Packets Recv	Number of RTP packets received
Bytes Sent	Number of RTP bytes sent
Bytes Recv	Number of RTP bytes received
Decode Latency	Decoder latency in milliseconds
Jitter	Receiver jitter in milliseconds
Round Trip Delay	Network round trip delay (ms); available if the peer supports RTCP
Packets Lost	Total number of packets lost
Packet Error	Number of RTP packets received that are invalid
Mapped RTP Port	NAT mapped RTP port

6.2. Enabling Logging and Debugging

The PHONE ADAPTER uses the following parameters to enable logging and debugging (both using the syslog protocol over UDP.)

- Syslog_Server
- Debug_Server
- Debug_Level

6.3. Error and Log Reporting

The PHONE ADAPTER Error Status Code (ESC) is used to indicate the current operation status of the PHONE ADAPTER unit. An error state can be a relatively long transient state or a steady state. The state is also represented by a special blinking pattern of the Status LED (next to the RJ-11 ports). The Error Status Code is a 4 digit number. The first digit indicates the error class: 1xxx represents normal operation states while 2xxx – 9xxx represent error states that must be fixed for the unit to function properly. The status code values can be read from the IVR option XXX or from the PHONE ADAPTER web-page.

6.4. Internal Error Codes

The PHONE ADAPTER defines a number of internal error codes (X00–X99) to facilitate configuration in providing finer control over the behavior of the unit under certain error conditions. They can be viewed as extensions to the SIP response codes 100–699. The definitions are shown below

Error Code	Description
X00	Transport layer (or ICMP) error when sending a SIP request
X20	SIP request times out while waiting for a response

X40	General SIP Protocol Error (e.g., unacceptable codec in SDP in 200 and ACK messages, or times out while waiting for ACK)
X60	Dialed number invalid according to given dial plan

6.5. Provisioning and Upgrade result codes

The \$PRVST and \$UPGST macro variables expand to integer codes which report the state of a resync or upgrade attempt. They are typically used within triggers and resync/upgrade conditions. The values of these variables is as follows:

- 1 = explicit request (resync/upgrade url or sip)
- 0 = just rebooted (resync only)
- 1 = triggered from configured trigger or rule
- 2 = error retry

6.6. Table of SIP Response Codes (Error Codes)

For convenience, below is a list of SIP error codes at the time of this printing which incorporates response codes from the IANA (Internet Assigned Numbers Authority) SIP parameter registry (<http://www.iana.org/assignments/sip-parameters>), and additional response codes defined in Internet-drafts which are implemented by the PHONE ADAPTER.

Provisional 1xx

- 100 Trying
- 180 Ringing
- 181 Call Is Being Forwarded
- 182 Queued
- 183 Session Progress

Successful 2xx

- 200 OK
- 202 Accepted

Redirection 3xx

- 300 Multiple Choices
- 301 Moved Permanently
- 302 Moved Temporarily
- 305 Use Proxy
- 380 Alternative Service

Request Failure 4xx

- 400 Bad Request
- 401 Unauthorized
- 402 Payment Required
- 403 Forbidden
- 404 Not Found
- 405 Method Not Allowed
- 406 Not Acceptable
- 407 Proxy Authentication Required
- 408 Request Timeout

410 Gone
412 Conditional Request Failed
413 Request Entity Too Large
414 Request-URI Too Long
415 Unsupported Media Type
416 Unsupported URI Scheme
420 Bad Extension
421 Extension Required
423 Interval Too Brief
429 Provide Referrer Identity
480 Temporarily Unavailable
481 Call/Transaction Does Not Exist
482 Loop Detected
483 Too Many Hops
484 Address Incomplete
485 Ambiguous
486 Busy Here
487 Request Terminated
488 Not Acceptable Here
489 Bad Event
491 Request Pending
493 Undecipherable
494 Security Agreement Required

Server Failure 5xx

500 Server Internal Error
501 Not Implemented
502 Bad Gateway
503 Service Unavailable
504 Server Time-out
505 Version Not Supported
513 Message Too Large
580 Precondition Failure

Global Failures 6xx

600 Busy Everywhere
603 Decline
604 Does Not Exist Anywhere
606 Not Acceptable

7. Summary of Implemented Features and Specifications

The PHONE ADAPTER is a full featured, fully programmable phone adapter that can be custom provisioned within a wide range of configuration parameters. The below feature descriptions are written as a high-level overview to provide a basic understanding of the feature breadth and capabilities of the PHONE ADAPTER. To understand the specific implementation of the below features, including parameters, requirements and contingencies please refer the section PHONE ADAPTER Feature Configuration Parameters, section **Error! Reference source not found.**

7.1. Data Networking Features

7.1.1. MAC Address (IEEE 802.3)

- 7.1.2. IPv4 – Internet Protocol Version 4 (RFC 791) upgradeable to v6 (RFC 1883)
- 7.1.3. ARP – Address Resolution Protocol
- 7.1.4. DNS – A Record (RFC 1706), SRV Record (RFC 2782)
- 7.1.5. DiffServ (RFC 2475) and ToS – Type of Service (RFC 791/1349)
- 7.1.6. DHCP Client – Dynamic Host Configuration Protocol (RFC 2131)
- 7.1.7. ICMP – Internet Control Message Protocol (RFC792)
- 7.1.8. TCP – Transmission Control Protocol (RFC793)
- 7.1.9. UDP – User Datagram Protocol (RFC768)
- 7.1.10. RTP – Real Time Protocol (RFC 1889) (RFC 1890)
- 7.1.11. RTCP – Real Time Control Protocol (RFC 1889)

7.2. Voice Features

7.2.1. SIPv2 – Session Initiation Protocol Version 2 (RFC 3261-3265)

7.2.1.1. SIP Proxy Redundancy – Static or Dynamic via DNS SRV

In typical commercial IP Telephony deployments, all calls are established through a SIP proxy server. An average SIP proxy server may handle tens of thousands subscribers. It is important that a backup server is available so that an active server can be temporarily switched out for maintenance. The PHONE ADAPTER supports the use of backup SIP proxy servers so that service disruption should be next to non-existent.

Static Redundancy:

A relatively simple way to support proxy redundancy is to configure a static list of SIP proxy servers to the PHONE ADAPTER in its configuration profile where the list is arranged in some order of priority. The PHONE ADAPTER will attempt to contact the highest priority proxy server whenever possible. When the currently selected proxy server is not responding, the PHONE ADAPTER automatically retries the next proxy server in the list.

Dynamic Redundancy:

The dynamic nature of SIP message routing makes the use of a static list of proxy servers inadequate in some scenarios. In deployments where user agents are served by different domains, for instance, it would not be feasible to configure one static list of proxy servers per covered domain into an PHONE ADAPTER. One solution to this situation is through the use DNS SRV records. The PHONE ADAPTER can be instructed to contact a SIP proxy server in a domain named in SIP messages. The PHONE ADAPTER shall consult the DNS server to get a list of hosts in the given domain that provides SIP services. If an entry exists, the DNS server will return a SRV record which contains a list of SIP proxy servers for the domain, with their host names, priority, listening ports, etc. The PHONE ADAPTER shall try to contact the list of hosts in the order of their stated priority.

7.2.1.2. Re-registration with Primary SIP Proxy Server

If the PHONE ADAPTER is currently using a lower priority proxy server, it should periodically probe the higher priority proxy to see if it is back on line and attempt to switch back to the higher priority proxy whenever possible. It is very important that switching proxy server should not affect calls that are already in progress.

7.2.1.3. SIP Support in Network Address Translation Networks – NAT

7.2.2. Codec Name Assignment

Negotiation of the optimal voice codec is sometimes dependent on the PHONE ADAPTER device's ability to "match" a codec name with the far-end device/gateway codec name. The PHONE ADAPTER allows the network administrator to individually name the various codecs that are supported such that the correct codec successfully negotiates with the far end the equipment.

7.2.3. Secure Calls

A user (if enabled by service provider or administrator) has the option to make an outbound call secure in the sense that the audio packets in both directions are encrypted.

7.2.4. Voice Algorithms:

7.2.4.1. G.711 (A-law and μ -law)

This very low complexity codec supports uncompressed 64 kbps digitized voice transmission at one through ten 5 ms voice frames per packet. This codec provides the highest voice quality and uses the most bandwidth of any of the available codecs.

7.2.4.2. G.726

This low complexity codec supports compressed 16, 24, 32 and 40 kbps digitized voice transmission at one through ten 10 ms voice frames per packet. This codec provides the high voice quality.

7.2.4.3. G.729A

The ITU G.729 voice coding algorithm is used to compress digitized speech. Linksys supports G.729. G.729A is a reduced complexity version of G.729. It requires about half the processing power to code G.729. The G.729 and G.729A bit streams are compatible and interoperable, but not identical.

7.2.4.4. G.723.1

The PHONE ADAPTER supports the use of ITU G.723.1 audio codec at 6.4 kbps. Up to 2 channels of G.723.1 can be used simultaneously. For example, Line 1 and Line 2 can be using G.723.1 simultaneously, or Line 1 or Line 2 can initiate a 3-way conference with both call legs using G.723.1.

7.2.5. Codec Selection

The administrator can select which low-bit-rate codec to be used for each line. G711a and G711u are always enabled.

7.2.6. Dynamic Payload

When no static payload value is assigned per RFC 1890, the PHONE ADAPTER can support dynamic payloads for G.726.

7.2.7. Adjustable Audio Frames Per Packet

This feature allows the user to set the number of audio frames contained in one RTP packet. Packets can be adjusted to contain from 1 – 10 audio frames. Increasing the number of packets decreases the bandwidth utilized – but it also increases delay and may affect voice quality.

7.2.8. Fax Tone Detection Pass-Through

Users can connect a fax terminal to the PHONE ADAPTER telephone port(s). Fax terminals transmit a single tone when they answer a call. The PHONE ADAPTER detects the type of equipment in use on the basis of its answer tone. When it detects the equipment answering the call, the PHONE ADAPTER performs a switchover from the current audio codec to G.711 codec.

7.2.9. DTMF: In-band & Out-of-Band (RFC 2833) (SIP INFO *)

The PHONE ADAPTER may relay DTMF digits as out-of-band events to preserve the fidelity of the digits. This can enhance the reliability of DTMF transmission required by many IVR applications such as dial-up banking and airline information.

7.2.10. Call Progress Tone Generation

The PHONE ADAPTER has configurable call progress tones. Parameters for each type of tone may include number of frequency components, frequency and amplitude of each component, and cadence information.

7.2.11. Call Progress Tone Pass Through

This feature allows the user to hear the call progress tones (such as ringing) that are generated from the far-end network.

7.2.12. Jitter Buffer – Dynamic (Adaptive)

The PHONE ADAPTER can buffer incoming voice packets to minimize out-of-order packet arrival. This process is known as jitter buffering. The Jitter Buffer size will proactively adjust or adapt in size depending on changing network conditions.

The PHONE ADAPTER has a Network Jitter Level control setting for each line of service. The jitter level decides how aggressively the PHONE ADAPTER will try to shrink the jitter buffer over time to achieve a lower overall delay. If the jitter level is higher, it shrinks more gradually. If jitter level is lower, it shrinks more quickly.

7.2.13. Full Duplex Audio

Full-duplex is the ability to communicate in two directions simultaneously so that more than one person can speak at a time. Half-duplex means that only one person can talk at a time – like a CB radio or walkie-talkie, which is unnatural in normal free-flowing two-way communications. The PHONE ADAPTER supports full-duplex audio.

7.2.14. Echo Cancellation – Up to 8 ms Echo Tail

The PHONE ADAPTER supports hybrid line echo cancellation. This feature uses the G.165 echo canceller to eliminate up to 8 ms of line echo. This feature does not provide acoustic echo cancellation on endpoint devices – that is, an end user's speakerphone.

7.2.15. Voice Activity Detection with Silence Suppression & Comfort Noise Generation

Voice Activity Detection (VAD) and Silence Suppression is a means of increasing the number of calls supported by the network by reducing the required bi-directional bandwidth for a single call. VAD uses a very sophisticated algorithm to distinguish between speech and non-speech signals. Based upon the current and past statistics, the VAD algorithm decides whether or not speech is present. If the VAD algorithm decides speech is not present, the silence suppression and comfort noise generation is activated. This is accomplished by removing and not transmitting the natural silence that occurs in normal 2-way connection – the IP bandwidth is used only when someone is speaking. During the silent periods of a telephone call additional bandwidth is available for other voice calls or data traffic since the silence packets are not being transmitted across the network. Comfort Noise Generation provides artificially generated background white noise (sounds), designed to reassure callers that their calls are still connected during silent periods. If Comfort Noise Generation is not used, the caller may think the call has been disconnected because of the “dead silence” periods created by the VAD and Silence Suppression feature.

7.2.16. Attenuation / Gain Adjustment

7.2.17. Signaling Hook Flash Event

The PHONE ADAPTER can signal hook flash events to the remote party on a connected call. This feature can be used to provide advanced mid-call services with third-party-call-control. Depending on the features that the service provider will offer using third-party-call-control, the following three PHONE ADAPTER features may be disabled to correctly signal a hook-flash event to the softswitch:

1. Call Waiting Service
2. Three Way Call Service
3. Three Way Conf Service

7.2.18. Configurable Flash / Switch Hook Timer

7.2.19. Configurable Dial Plan with Interdigit Timers

The PHONE ADAPTER has three configurable interdigit timers:

- Initial timeout (T) = handset off hook, no digit pressed yet.
- Long timeout (L) = one or more digits pressed, more digits needed to reach a valid number (as per the dial plan).
- Short timeout (S) = current dialed number is valid, but more digits would also lead to a valid number.

7.2.20. Message Waiting Indicator Tones – MWI

7.2.21. Polarity Control

The PHONE ADAPTER allows the polarity to be set when a call is connected and when a call is disconnected. This feature is required to support some pay phone system and answering machines.

7.2.22. Calling Party Control – CPC

CPC signals to the called party equipment that the calling party has hung up during a connected call by removing the voltage between the tip and ring momentarily. This feature is useful for auto-answer equipment which then knows when to disengage.

7.2.23. International Caller ID Delivery

In addition to support of the Bellcore (FSK) and Swedish/Danish (DTMF) methods of Caller ID (CID) delivery, release 2.0 adds a large subset of ETSI compliant methods to support international CID equipment. The figure below shows the CID/CIDCW architecture used in the PHONE ADAPTER. Different flavors of CID delivery method can be obtained by mixing-and-matching some of the steps as shown.

It should be noted that the choice of CID method will affect the following features:

- On Hook Caller ID Associated with Ringing – This type of Caller ID is used for incoming calls when the attached phone is on hook (see Figure 1 (a) – (c)). All PHONE ADAPTER CID methods can be applied for this type of caller-id
- On Hook Caller ID Not Associated with Ringing – In the PHONE ADAPTER this feature is used for send VMWI signal to the phone to turn the message waiting light on and off (see Figure 1 (d) and (e)). This is available only for FSK-based caller-id methods: “Bellcore”, “ETSI FSK”, and “ETSI FSK With PR”
- Off Hook Caller ID – This is used to delivery caller-id on incoming calls when the attached phone is off hook (see Figure 1 (f)). This can be call waiting caller ID (CIDCW) or to notify the user that the far end party identity has changed or updated (such as due to a call transfer). This is only available if the caller-id method is one of “Bellcore”, “ETSI FSK”, or “ETSI FSK With PR”.

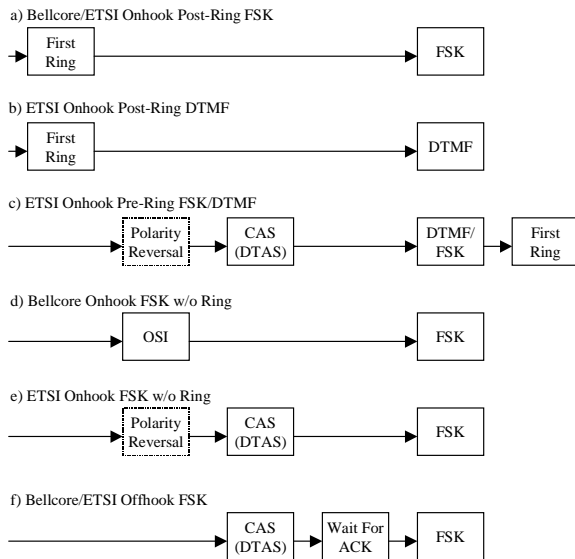

PHONE ADAPTER Caller ID Delivery Architecture

7.2.24. Streaming Audio Server – SAS

This feature allows one to attach an audio source to one of the PHONE ADAPTER FXS ports and use it as a streaming audio source device. The corresponding Line (1 or 2) can be configured as a streaming audio server (SAS) such that when the Line is called, the PHONE ADAPTER answers the call automatically and starts streaming audio to the calling party provided the FXS port is off-hook. If the FXS port is on-hook when the incoming call arrives, the PHONE ADAPTER replies with a SIP 503 response code to indicate “Service Not Available.” If an incoming call is auto-answered, but later the FXS port becomes on-hook, the PHONE ADAPTER does not terminate the call but continues to stream silence packets to the caller. If an incoming call arrives when the SAS line has reached full capacity, the PHONE ADAPTER replies with a SIP 486 response code to indicate “Busy Here”.

The SAS line can be setup to refresh each streaming audio session periodically (via SIP re-INVITE) to detect if the connection to the caller is down. If the caller does not respond to the refresh message, the SAS line will terminate the call so that the streaming resource can be used for other callers.

7.2.25. Music On Hold – MOH

On a connected call, the PHONE ADAPTER may place the remote party on call (the only way to do this on the PHONE ADAPTER is to perform a hook-flash to initiate a 3-way call or to swap 2 calls during call-waiting). If the remote party indicates that they can still receive audio while the call is holding, the PHONE ADAPTER can be setup to contact an auto-answering SAS as described in Section 4 and have it stream audio to the holding party. When used this way, the SAS is referred to as a MOH Server.

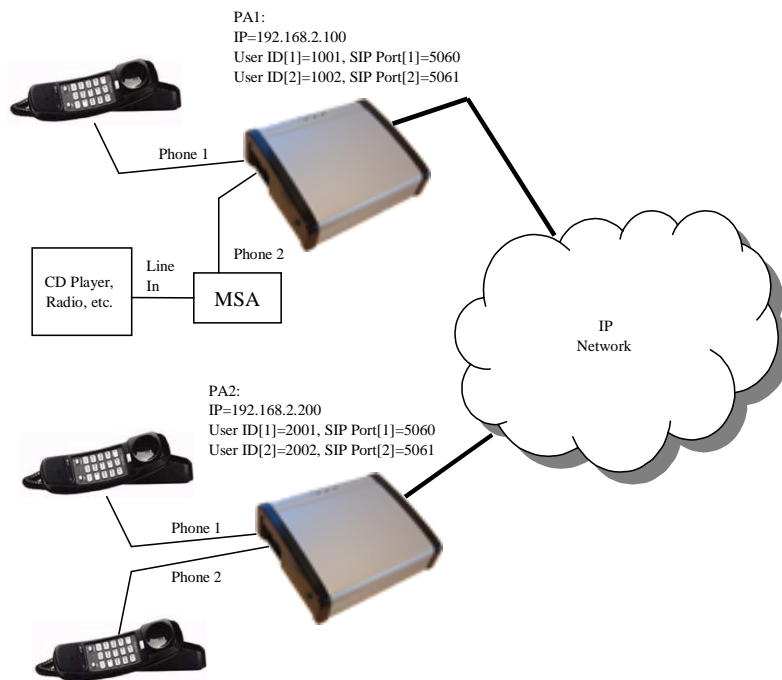

Example configuration for MOH application with a PHONE ADAPTER line configured as a SAS
SAS Configuration Examples:

The following configuration examples are based on the setup as depicted in Figure.

Example 1: SAS Line not registered with the Proxy Server for the other subscribers

On PHONE ADAPTER 1:

SAS Enable[1] = no

MOH Server [1] = 1002@192.168.2.100:5061 or 1002@127.0.0.1:5061

SAS Enable[2] = yes

On PHONE ADAPTER 2:

SAS Enable[1] = no

MOH Server [1] = 1002@192.168.2.100:5061

SAS Enable[2] = no

MOH Server [2] = 1002@192.168.2.100:5061

Example 2: SAS Line registered with the Proxy Server as the other subscribers

On PHONE ADAPTER 1:

SAS Enable[1] = no

MOH Server [1] = 1002

SAS Enable[2] = yes

On PHONE ADAPTER 2:

SAS Enable[1] = no

MOH Server [1] = 1002

SAS Enable[2] = no

MOH Server [2] = 1002

7.3. Security Features

7.3.1. Multiple Administration Layers (Levels and Permissions)

7.3.2. HTTP Digest – Encrypted Authentication via MD5 (RFC 1321)

7.3.3. HTTPS with Client Certificate

7.4. Administration and Maintenance Features

7.4.1. Web Browser Administration and Configuration via Integral Web Server

7.4.2. Telephone Key Pad Configuration with Interactive Voice Prompts

7.4.3. Automated Provisioning & Upgrade via TFTP, HTTP and HTTPS

7.4.4. Periodic Notification of Upgrade Availability via NOTIFY or HTTP

7.4.5. Non-Intrusive, In-Service Upgrades

7.4.6. Report Generation and Event Logging

The PHONE ADAPTER reports a variety of status and error reports to assist service providers to diagnose problems and evaluate the performance of their services. The information can be queried by an authorized agent (using HTTP with digested authentication, for instance). The information may be organized as an XML page or HTML page.

7.4.7. Syslog and Debug Server Records

The PHONE ADAPTER supports detailed logging of all activities for further debugging. The debug information may be sent to a configured Syslog server. Via the configuration parameters, the PHONE ADAPTER allows some settings to select which type of activity/events should be logged – for instance, a debug level setting.

8. List of all configuration parameters

Below is a list of all the configuration parameters for this software version (2.0.9). To obtain this list for another version of software, run the profile compiler utility (spc).

```
# ***
# *** Linksys PHONE ADAPTER Series Configuration Parameters
# ***

# *** System Configuration

Restricted_Access_Domains      "" ;
Enable_Web_Server             "Yes" ;
Web_Server_Port                "80" ;
```

```

Enable_Web_Admin_Access      "Yes" ;
Admin_Passwd                 " " ;
User_Password                 ! " " ;

# *** Internet Connection Type

DHCP                          ! "Yes" ;
Static_IP                    ! " " ;
NetMask                       ! " " ;
Gateway                       ! " " ;

# *** Optional Network Configuration

HostName                       ! " " ;
Domain                        ! " " ;
Primary_DNS                    ! " " ;
Secondary_DNS                  ! " " ;
DNS_Server_Order              "Manual" ; # options:
    Manual/Manual,DHCP/DHCP,Manual
DNS_Query_Mode                "Parallel" ; # options: Parallel/Sequential
Syslog_Server                 " " ;
Debug_Server                  " " ;
Debug_Level                   "0" ; # options: 0/1/2/3
Primary_NTP_Server            " " ;
Secondary_NTP_Server          " " ;

# *** Configuration Profile

Provision_Enable              "Yes" ;
Resync_On_Reset               "Yes" ;
Resync_Random_Delay           "2" ;
Resync_Periodic               "3600" ;
Resync_Error_Retry_Delay      "3600" ;
Forced_Resync_Delay           "14400" ;
Resync_From_SIP               "Yes" ;
Resync_After_Upgrade_Attempt "Yes" ;
Resync_Trigger_1              " " ;
Resync_Trigger_2              " " ;
Resync_Fails_On_FNF          "No" ;
Profile_Rule                  "/init.cfg" ;
Profile_Rule_B                 " " ;
Profile_Rule_C                 " " ;
Profile_Rule_D                 " " ;
Log_Resync_Request_Msg        "$PN $MAC -- Requesting resync
    $SCHEME://$SERVIP:$PORT$PATH" ;
Log_Resync_Success_Msg        "$PN $MAC -- Successful resync
    $SCHEME://$SERVIP:$PORT$PATH" ;
Log_Resync_Failure_Msg        "$PN $MAC -- Resync failed: $ERR" ;

# *** Firmware Upgrade

Upgrade_Enable                "Yes" ;
Upgrade_Error_Retry_Delay     "3600" ;
Downgrade_Rev_Limit           " " ;
Upgrade_Rule                   " " ;
Log_Upgrade_Request_Msg       "$PN $MAC -- Requesting upgrade
    $SCHEME://$SERVIP:$PORT$PATH" ;
Log_Upgrade_Success_Msg       "$PN $MAC -- Successful upgrade
    $SCHEME://$SERVIP:$PORT$PATH -- $ERR" ;
Log_Upgrade_Failure_Msg       "$PN $MAC -- Upgrade failed: $ERR" ;

# *** General Purpose Parameters

GPP_A                          " " ;
GPP_B                          " " ;
GPP_C                          " " ;
GPP_D                          " " ;
GPP_E                          " " ;
GPP_F                          " " ;

```

```

GPP_G           "" ;
GPP_H           "" ;
GPP_I           "" ;
GPP_J           "" ;
GPP_K           "" ;
GPP_L           "" ;
GPP_M           "" ;
GPP_N           "" ;
GPP_O           "" ;
GPP_P           "" ;
GPP_SA          "" ;
GPP_SB          "" ;
GPP_SC          "" ;
GPP_SD          "" ;

# *** SIP Parameters

Max_Forward     "70" ;
Max_Redirection "5" ;
Max_Auth        "2" ;
SIP_User_Agent_Name "$VERSION" ;
SIP_Server_Name "$VERSION" ;
SIP_Accept_Language "" ;
DTMF_Relay_MIME_Type "application/dtmf-relay" ;
Hook_Flash_MIME_Type "application/hook-flash" ;
Remove_Last_Reg "No" ;
Use_Compact_Header "No" ;

# *** SIP Timer Values (sec)

SIP_T1          ".5" ;
SIP_T2          "4" ;
SIP_T4          "5" ;
SIP_Timer_B     "32" ;
SIP_Timer_F     "32" ;
SIP_Timer_H     "32" ;
SIP_Timer_D     "32" ;
SIP_Timer_J     "32" ;
INVITE_Expires "240" ;
ReINVITE_Expires "30" ;
Reg_Min_Expires "1" ;
Reg_Max_Expires "7200" ;
Reg_Retry_Intvl "30" ;
Reg_Retry_Long_Intvl "1200" ;

# *** Response Status Code Handling

SIT1_RSC        "" ;
SIT2_RSC        "" ;
SIT3_RSC        "" ;
SIT4_RSC        "" ;
Try_Backup_RSC  "" ;
Retry_Reg_RSC   "" ;

# *** RTP Parameters

RTP_Port_Min    "16384" ;
RTP_Port_Max    "16482" ;
RTP_Packet_Size "0.030" ;
Max_RTP_ICMP_Err "0" ;
RTCP_Tx_Interval "0" ;

# *** SDP Payload Types

NSE_Dynamic_Payload "100" ;
AVT_Dynamic_Payload "101" ;
G726r16_Dynamic_Payload "98" ;
G726r24_Dynamic_Payload "97" ;
G726r40_Dynamic_Payload "96" ;

```



```

G729b_Dynamic_Payload          "99" ;
NSE_Codec_Name                  "NSE" ;
AVT_Codec_Name                  "telephone-event" ;
G711u_Codec_Name               "PCMU" ;
G711a_Codec_Name               "PCMA" ;
G726r16_Codec_Name             "G726-16" ;
G726r24_Codec_Name             "G726-24" ;
G726r32_Codec_Name             "G726-32" ;
G726r40_Codec_Name             "G726-40" ;
G729a_Codec_Name               "G729a" ;
G729b_Codec_Name               "G729ab" ;
G723_Codec_Name                 "G723" ;

# *** NAT Support Parameters

Handle_VIA_received             "No" ;
Handle_VIA_rport                "No" ;
Insert_VIA_received             "No" ;
Insert_VIA_rport                "No" ;
Substitute_VIA_Addr            "No" ;
Send_Resp_To_Src_Port          "No" ;
STUN_Enable                     "No" ;
STUN_Test_Enable               "No" ;
STUN_Server                     "" ;
EXT_IP                           "" ;
EXT_RTP_Port_Min                "" ;
NAT_Keep_Alive_Intvl           "15" ;

# ***

Line_Enable[1]                  "Yes" ;

# *** Streaming Audio Server (SAS)

SAS_Enable[1]                   "No" ;
SAS_DLG_Refresh_Intvl[1]        "30" ;
SAS_Inbound_RTP_Sink[1]         "" ;

# *** NAT Settings

NAT_Mapping_Enable[1]           "No" ;
NAT_Keep_Alive_Enable[1]        "No" ;
NAT_Keep_Alive_Msg[1]           "$NOTIFY" ;
NAT_Keep_Alive_Dest[1]          "$PROXY" ;

# *** Network Settings

SIP_TOS/DiffServ_Value[1]       "0x68" ;
Network_Jitter_Level[1]         "high" ; # options: low/medium/high/very high
RTP_TOS/DiffServ_Value[1]       "0xb8" ;

# *** SIP Settings

SIP_Port[1]                     "5060" ;
SIP_100REL_Enable[1]            "No" ;
EXT_SIP_Port[1]                  "" ;
Auth_Resync-Reboot[1]           "Yes" ;
SIP_Debug_Option[1]             "none" ; # options: none/1-line/1-line excl.
    OPT/1-line excl. NTFY/1-line excl. REG/1-line excl. OPT|NTFY|REG/full/full excl.
    OPT/full excl. NTFY/full excl. REG/full excl. OPT|NTFY|REG

# *** Call Feature Settings

Blind_Attn-Xfer_Enable[1]       "No" ;
MOH_Server[1]                    "" ;
Xfer_When_Hangup_Conf[1]        "Yes" ;

# *** Proxy and Registration

```

```

Proxy[1] " " ;
Use_Outbound_Proxy[1] "No" ;
Outbound_Proxy[1] " " ;
Use_OB_Proxy_In_Dialog[1] "Yes" ;
Register[1] "Yes" ;
Make_Call_Without_Reg[1] "No" ;
Register_Expires[1] "3600" ;
Ans_Call_Without_Reg[1] "No" ;
Use_DNS_SRV[1] "No" ;
DNS_SRV_Auto_Prefix[1] "No" ;
Proxy_Fallback_Intvl[1] "3600" ;
Voice_Mail_Server[1] " " ;

# *** Subscriber Information

Display_Name[1] " " ;
User_ID[1] " " ;
Password[1] " " ;
Use_Auth_ID[1] "No" ;
Auth_ID[1] " " ;
Mini_Certificate[1] " " ;
SRTP_Private_Key[1] " " ;

# *** Supplementary Service Subscription

Call_Waiting_Serv[1] "Yes" ;
Block_CID_Serv[1] "Yes" ;
Block_ANC_Serv[1] "Yes" ;
Dist_Ring_Serv[1] "Yes" ;
Cfwd_All_Serv[1] "Yes" ;
Cfwd_Busy_Serv[1] "Yes" ;
Cfwd_No_Ans_Serv[1] "Yes" ;
Cfwd_Sel_Serv[1] "Yes" ;
Cfwd_Last_Serv[1] "Yes" ;
Block_Last_Serv[1] "Yes" ;
Accept_Last_Serv[1] "Yes" ;
DND_Serv[1] "Yes" ;
CID_Serv[1] "Yes" ;
CWCID_Serv[1] "Yes" ;
Call_Return_Serv[1] "Yes" ;
Call_Back_Serv[1] "Yes" ;
Three_Way_Call_Serv[1] "Yes" ;
Three_Way_Conf_Serv[1] "Yes" ;
Attn_Transfer_Serv[1] "Yes" ;
Unattn_Transfer_Serv[1] "Yes" ;
MWI_Serv[1] "Yes" ;
VMWI_Serv[1] "Yes" ;
Speed_Dial_Serv[1] "Yes" ;
Secure_Call_Serv[1] "Yes" ;
Referral_Serv[1] "Yes" ;
Feature_Dial_Serv[1] "Yes" ;

# *** Audio Configuration

Preferred_Codec[1] "G711u" ; # options: G711u/G711a/G726-16/
G726-24/G726-32/G726-40/G729a/G723
Silence_Supp_Enable[1] "No" ;
Use_Pref_Codec_Only[1] "No" ;
Echo_Canc_Enable[1] "Yes" ;
G729a_Enable[1] "Yes" ;
Echo_Canc_Adapt_Enable[1] "Yes" ;
G723_Enable[1] "Yes" ;
Echo_Supp_Enable[1] "Yes" ;
G726-16_Enable[1] "Yes" ;
FAX_CED_Detect_Enable[1] "Yes" ;
G726-24_Enable[1] "Yes" ;
FAX_CNG_Detect_Enable[1] "Yes" ;
G726-32_Enable[1] "Yes" ;
FAX_Passthru_Codec[1] "G711u" ; # options: G711u/G711a

```

```

G726-40_Enable[1]                "Yes" ;
FAX_Codec_Symmetric[1]           "Yes" ;
DTMF_Tx_Method[1]                "Auto" ; # options: InBand/AVT/INFO/Auto
FAX_Passthru_Method[1]           "NSE" ; # options: None/NSE/ReINVITE
Hook_Flash_Tx_Method[1]          "None" ; # options: None/AVT/INFO
FAX_Process_NSE[1]               "Yes" ;
Release_Unused_Codec[1]           "Yes" ;

# *** Dial Plan

Dial_Plan[1] "(*xx|[3469]11|0|00|[2-9]xxxxxx|1xxx[2-9]xxxxxxS0|xxxxxxxxxxxxx.)" ;
Enable_IP_Dialing[1]              "No" ;

# *** FXS Port Polarity Configuration

Idle_Polarity[1]                  "Forward" ; # options: Forward/Reverse
Caller_Conn_Polarity[1]           "Forward" ; # options: Forward/Reverse
Callee_Conn_Polarity[1]          "Forward" ; # options: Forward/Reverse

# *** Call Forward Settings

Cfwd_All_Dest[1]                  ! "" ;
Cfwd_Busy_Dest[1]                 ! "" ;
Cfwd_No_Ans_Dest[1]               ! "" ;
Cfwd_No_Ans_Delay[1]              ! "20" ;

# *** Selective Call Forward Settings

Cfwd_Sel1_Caller[1]               ! "" ;
Cfwd_Sel1_Dest[1]                 ! "" ;
Cfwd_Sel2_Caller[1]               ! "" ;
Cfwd_Sel2_Dest[1]                 ! "" ;
Cfwd_Sel3_Caller[1]               ! "" ;
Cfwd_Sel3_Dest[1]                 ! "" ;
Cfwd_Sel4_Caller[1]               ! "" ;
Cfwd_Sel4_Dest[1]                 ! "" ;
Cfwd_Sel5_Caller[1]               ! "" ;
Cfwd_Sel5_Dest[1]                 ! "" ;
Cfwd_Sel6_Caller[1]               ! "" ;
Cfwd_Sel6_Dest[1]                 ! "" ;
Cfwd_Sel7_Caller[1]               ! "" ;
Cfwd_Sel7_Dest[1]                 ! "" ;
Cfwd_Sel8_Caller[1]               ! "" ;
Cfwd_Sel8_Dest[1]                 ! "" ;
Cfwd_Last_Caller[1]               ! "" ;
Cfwd_Last_Dest[1]                 ! "" ;
Block_Last_Caller[1]              ! "" ;
Accept_Last_Caller[1]             ! "" ;

# *** Speed Dial Settings

Speed_Dial_2[1]                   ! "" ;
Speed_Dial_3[1]                   ! "" ;
Speed_Dial_4[1]                   ! "" ;
Speed_Dial_5[1]                   ! "" ;
Speed_Dial_6[1]                   ! "" ;
Speed_Dial_7[1]                   ! "" ;
Speed_Dial_8[1]                   ! "" ;
Speed_Dial_9[1]                   ! "" ;

# *** Supplementary Service Settings

CW_Setting[1]                     ! "Yes" ;
Block_CID_Setting[1]              ! "No" ;
Block_ANC_Setting[1]              ! "No" ;
DND_Setting[1]                    ! "No" ;
CID_Setting[1]                    ! "Yes" ;
CWCID_Setting[1]                  ! "Yes" ;
Dist_Ring_Setting[1]              ! "Yes" ;

```

```

Secure_Call_Setting[1]          "No" ;

# *** Distinctive Ring Settings

Ring1_Caller[1]                 ! "" ;
Ring2_Caller[1]                 ! "" ;
Ring3_Caller[1]                 ! "" ;
Ring4_Caller[1]                 ! "" ;
Ring5_Caller[1]                 ! "" ;
Ring6_Caller[1]                 ! "" ;
Ring7_Caller[1]                 ! "" ;
Ring8_Caller[1]                 ! "" ;

# *** Ring Settings

Default_Ring[1]                 ! "1" ; # options: 1/2/3/4/5/6/7/8
Default_CWT[1]                  ! "1" ; # options: 1/2/3/4/5/6/7/8
Hold_Reminder_Ring[1]           ! "8" ; # options: 1/2/3/4/5/6/7/8/none
Call_Back_Ring[1]              ! "7" ; # options: 1/2/3/4/5/6/7/8
Cfwd_Ring_Splash_Len[1]        ! "0" ;
Cblk_Ring_Splash_Len[1]        ! "0" ;
VMWI_Ring_Splash_Len[1]        ! ".5" ;
VMWI_Ring_Policy[1]            "New VM Available" ; # options: New VM
    Available/New VM Becomes Available/New VM Arrives
Ring_On_No_New_VM[1]           "No" ;

# ***

Line_Enable[2]                  "Yes" ;

# *** Streaming Audio Server (SAS)

SAS_Enable[2]                   "No" ;
SAS_DLG_Refresh_Intvl[2]        "30" ;
SAS_Inbound_RTP_Sink[2]         "" ;

# *** NAT Settings

NAT_Mapping_Enable[2]           "No" ;
NAT_Keep_Alive_Enable[2]        "No" ;
NAT_Keep_Alive_Msg[2]           "$NOTIFY" ;
NAT_Keep_Alive_Dest[2]          "$PROXY" ;

# *** Network Settings

SIP_TOS/DiffServ_Value[2]       "0x68" ;
Network_Jitter_Level[2]         "high" ; # options: low/medium/high/very high
RTP_TOS/DiffServ_Value[2]       "0xb8" ;

# *** SIP Settings

SIP_Port[2]                     "5061" ;
SIP_100REL_Enable[2]            "No" ;
EXT_SIP_Port[2]                 "" ;
Auth_Resync-Reboot[2]           "Yes" ;
SIP_Debug_Option[2]             "none" ; # options: none/1-line/1-line excl.
    OPT/1-line excl. NTFY/1-line excl. REG/1-line excl. OPT|NTFY|REG/full/full excl.
    OPT/full excl. NTFY/full excl. REG/full excl. OPT|NTFY|REG

# *** Call Feature Settings

Blind_Attn-Xfer_Enable[2]       "No" ;
MOH_Server[2]                   "" ;
Xfer_When_Hangup_Conf[2]        "Yes" ;

# *** Proxy and Registration

Proxy[2]                         "" ;
Use_Outbound_Proxy[2]           "No" ;

```

```

Outbound_Proxy[2]           " " ;
Use_OB_Proxy_In_Dialog[2]  "Yes" ;
Register[2]                 "Yes" ;
Make_Call_Without_Reg[2]   "No" ;
Register_Expires[2]        "3600" ;
Ans_Call_Without_Reg[2]    "No" ;
Use_DNS_SRV[2]             "No" ;
DNS_SRV_Auto_Prefix[2]     "No" ;
Proxy_Fallback_Intvl[2]    "3600" ;
Voice_Mail_Server[2]       " " ;

# *** Subscriber Information

Display_Name[2]            " " ;
User_ID[2]                 " " ;
Password[2]                " " ;
Use_Auth_ID[2]             "No" ;
Auth_ID[2]                 " " ;
Mini_Certificate[2]        " " ;
SRTP_Private_Key[2]        " " ;

# *** Supplementary Service Subscription

Call_Waiting_Serv[2]       "Yes" ;
Block_CID_Serv[2]          "Yes" ;
Block_ANC_Serv[2]          "Yes" ;
Dist_Ring_Serv[2]          "Yes" ;
Cfwd_All_Serv[2]           "Yes" ;
Cfwd_Busy_Serv[2]          "Yes" ;
Cfwd_No_Ans_Serv[2]        "Yes" ;
Cfwd_Sel_Serv[2]           "Yes" ;
Cfwd_Last_Serv[2]          "Yes" ;
Block_Last_Serv[2]         "Yes" ;
Accept_Last_Serv[2]        "Yes" ;
DND_Serv[2]                "Yes" ;
CID_Serv[2]                "Yes" ;
CWCID_Serv[2]              "Yes" ;
Call_Return_Serv[2]        "Yes" ;
Call_Back_Serv[2]          "Yes" ;
Three_Way_Call_Serv[2]     "Yes" ;
Three_Way_Conf_Serv[2]     "Yes" ;
Attn_Transfer_Serv[2]      "Yes" ;
Unattn_Transfer_Serv[2]    "Yes" ;
MWI_Serv[2]                "Yes" ;
VMWI_Serv[2]               "Yes" ;
Speed_Dial_Serv[2]         "Yes" ;
Secure_Call_Serv[2]        "Yes" ;
Referral_Serv[2]           "Yes" ;
Feature_Dial_Serv[2]       "Yes" ;

# *** Audio Configuration

Preferred_Codec[2]          "G711u" ; # options: G711u/G711a/G726-16/
    G726-24/G726-32/G726-40/G729a/G723
Silence_Supp_Enable[2]     "No" ;
Use_Pref_Codec_Only[2]     "No" ;
Echo_Canc_Enable[2]        "Yes" ;
G729a_Enable[2]            "Yes" ;
Echo_Canc_Adapt_Enable[2]  "Yes" ;
G723_Enable[2]             "Yes" ;
Echo_Supp_Enable[2]        "Yes" ;
G726-16_Enable[2]          "Yes" ;
FAX_CED_Detect_Enable[2]   "Yes" ;
G726-24_Enable[2]          "Yes" ;
FAX_CNG_Detect_Enable[2]   "Yes" ;
G726-32_Enable[2]          "Yes" ;
FAX_Passthru_Codec[2]      "G711u" ; # options: G711u/G711a
G726-40_Enable[2]          "Yes" ;
FAX_Codec_Symmetric[2]    "Yes" ;

```

```

DTMF_Tx_Method[2]                "Auto" ; # options: InBand/AVT/INFO/Auto
FAX_Passthru_Method[2]           "NSE" ; # options: None/NSE/ReINVITE
Hook_Flash_Tx_Method[2]         "None" ; # options: None/AVT/INFO
FAX_Process_NSE[2]              "Yes" ;
Release_Unused_Codec[2]          "Yes" ;

# *** Dial Plan

Dial_Plan[2] "(*xx|[3469]11|0|00|[2-9]xxxxxx|1xxx[2-9]xxxxxxS0|xxxxxxxxxxxxxx.)" ;
Enable_IP_Dialing[2]             "No" ;

# *** FXS Port Polarity Configuration

Idle_Polarity[2]                 "Forward" ; # options: Forward/Reverse
Caller_Conn_Polarity[2]         "Forward" ; # options: Forward/Reverse
Callee_Conn_Polarity[2]        "Forward" ; # options: Forward/Reverse

# *** Call Forward Settings

Cfwd_All_Dest[2]                 ! "" ;
Cfwd_Busy_Dest[2]               ! "" ;
Cfwd_No_Ans_Dest[2]             ! "" ;
Cfwd_No_Ans_Delay[2]            ! "20" ;

# *** Selective Call Forward Settings

Cfwd_Sel1_Caller[2]             ! "" ;
Cfwd_Sel1_Dest[2]              ! "" ;
Cfwd_Sel2_Caller[2]            ! "" ;
Cfwd_Sel2_Dest[2]              ! "" ;
Cfwd_Sel3_Caller[2]            ! "" ;
Cfwd_Sel3_Dest[2]              ! "" ;
Cfwd_Sel4_Caller[2]            ! "" ;
Cfwd_Sel4_Dest[2]              ! "" ;
Cfwd_Sel5_Caller[2]            ! "" ;
Cfwd_Sel5_Dest[2]              ! "" ;
Cfwd_Sel6_Caller[2]            ! "" ;
Cfwd_Sel6_Dest[2]              ! "" ;
Cfwd_Sel7_Caller[2]            ! "" ;
Cfwd_Sel7_Dest[2]              ! "" ;
Cfwd_Sel8_Caller[2]            ! "" ;
Cfwd_Sel8_Dest[2]              ! "" ;
Cfwd_Last_Caller[2]            ! "" ;
Cfwd_Last_Dest[2]              ! "" ;
Block_Last_Caller[2]           ! "" ;
Accept_Last_Caller[2]          ! "" ;

# *** Speed Dial Settings

Speed_Dial_2[2]                 ! "" ;
Speed_Dial_3[2]                 ! "" ;
Speed_Dial_4[2]                 ! "" ;
Speed_Dial_5[2]                 ! "" ;
Speed_Dial_6[2]                 ! "" ;
Speed_Dial_7[2]                 ! "" ;
Speed_Dial_8[2]                 ! "" ;
Speed_Dial_9[2]                 ! "" ;

# *** Supplementary Service Settings

CW_Setting[2]                   ! "Yes" ;
Block_CID_Setting[2]            ! "No" ;
Block_ANC_Setting[2]           ! "No" ;
DND_Setting[2]                  ! "No" ;
CID_Setting[2]                  ! "Yes" ;
CWCID_Setting[2]               ! "Yes" ;
Dist_Ring_Setting[2]           ! "Yes" ;
Secure_Call_Setting[2]          "No" ;

```

```

# *** Distinctive Ring Settings

Ring1 Caller[2]          ! "" ;
Ring2 Caller[2]          ! "" ;
Ring3 Caller[2]          ! "" ;
Ring4 Caller[2]          ! "" ;
Ring5 Caller[2]          ! "" ;
Ring6 Caller[2]          ! "" ;
Ring7 Caller[2]          ! "" ;
Ring8 Caller[2]          ! "" ;

# *** Ring Settings

Default_Ring[2]          ! "1" ; # options: 1/2/3/4/5/6/7/8
Default_CWT[2]           ! "1" ; # options: 1/2/3/4/5/6/7/8
Hold_Reminder_Ring[2]    ! "8" ; # options: 1/2/3/4/5/6/7/8/none
Call_Back_Ring[2]        ! "7" ; # options: 1/2/3/4/5/6/7/8
Cfwd_Ring_Splash_Len[2] ! "0" ;
Cblk_Ring_Splash_Len[2] ! "0" ;
VMWI_Ring_Splash_Len[2] ! ".5" ;
VMWI_Ring_Policy[2]      "New VM Available" ; # options: New VM
Available/New VM Becomes Available/New VM Arrives
Ring_On_No_New_VM[2]     "No" ;

# *** Call Progress Tones

Dial_Tone                 "350@-19,440@-19;10(*0/1+2)" ;
Second_Dial_Tone          "420@-19,520@-19;10(*0/1+2)" ;
Outside_Dial_Tone         "420@-16;10(*0/1)" ;
Prompt_Tone                "520@-19,620@-19;10(*0/1+2)" ;
Busy_Tone                  "480@-19,620@-19;10(.5/.5/1+2)" ;
Reorder_Tone               "480@-19,620@-19;10(.25/.25/1+2)" ;
Off_Hook_Warning_Tone     "480@-10,620@0;10(.125/.125/1+2)" ;
Ring_Back_Tone             "440@-19,480@-19;*(2/4/1+2)" ;
Confirm_Tone               "600@-16;1(.25/.25/1)" ;
SIT1_Tone                  "985@-16,1428@-16,1777@-16;
  20(.380/0/1,.380/0/2,.380/0/3,0/4/0)" ;
SIT2_Tone                  "914@-16,1371@-16,1777@-16;
  20(.274/0/1,.274/0/2,.380/0/3,0/4/0)" ;
SIT3_Tone                  "914@-16,1371@-16,1777@-16;
  20(.380/0/1,.380/0/2,.380/0/3,0/4/0)" ;
SIT4_Tone                  "985@-16,1371@-16,1777@-16;
  20(.380/0/1,.274/0/2,.380/0/3,0/4/0)" ;
MWI_Dial_Tone              "350@-19,440@-19;2(.1/.1/1+2);10(*0/1+2)" ;
Cfwd_Dial_Tone             "350@-19,440@-19;2(.2/.2/1+2);10(*0/1+2)" ;
Holding_Tone               "600@-19;*(.1/.1/1,.1/.1/1,.1/9.5/1)" ;
Conference_Tone            "350@-19;20(.1/.1/1,.1/9.7/1)" ;
Secure_Call_Indication_Tone "397@-19,507@-19;15(0/2/0,.2/.1/1,.1/2.1/2)" ;

# *** Distinctive Ring Patterns

Ring1_Cadence              "60(2/4)" ;
Ring2_Cadence              "60(.3/.2,1/.2,.3/4)" ;
Ring3_Cadence              "60(.8/.4,.8/4)" ;
Ring4_Cadence              "60(.4/.2,.3/.2,.8/4)" ;
Ring5_Cadence              "60(.2/.2,.2/.2,.2/.2,1/4)" ;
Ring6_Cadence              "60(.2/.4,.2/.4,.2/4)" ;
Ring7_Cadence              "60(.4/.2,.4/.2,.4/4)" ;
Ring8_Cadence              "60(0.25/9.75)" ;

# *** Distinctive Call Waiting Tone Patterns

CWT1_Cadence               "30(.3/9.7)" ;
CWT2_Cadence               "30(.1/.1,.1/9.7)" ;
CWT3_Cadence               "30(.1/.1,.3/.1,.1/9.3)" ;
CWT4_Cadence               "30(.1/.1,.1/.1,.1/9.5)" ;
CWT5_Cadence               "30(.3/.1,.1/.1,.3/9.1)" ;
CWT6_Cadence               "30(.1/.1,.3/.2,.3/9.1)" ;
CWT7_Cadence               "30(.3/.1,.3/.1,.1/9.1)" ;

```

```

CWT8_Cadence                "2.3(.3/2)" ;

# *** Distinctive Ring/CWT Pattern Names

Ring1_Name                  "Bellcore-r1" ;
Ring2_Name                  "Bellcore-r2" ;
Ring3_Name                  "Bellcore-r3" ;
Ring4_Name                  "Bellcore-r4" ;
Ring5_Name                  "Bellcore-r5" ;
Ring6_Name                  "Bellcore-r6" ;
Ring7_Name                  "Bellcore-r7" ;
Ring8_Name                  "Bellcore-r8" ;

# *** Ring and Call Waiting Tone Spec

Ring_Waveform               "Sinusoid" ; # options: Sinusoid/Trapezoid
Ring_Frequency              "25" ;
Ring_Voltage                "70" ;
CWT_Frequency               "440@-10" ;

# *** Control Timer Values (sec)

Hook_Flash_Timer_Min       ".1" ;
Hook_Flash_Timer_Max       ".9" ;
Callee_On_Hook_Delay      "0" ;
Reorder_Delay              "5" ;
Call_Back_Expires          "1800" ;
Call_Back_Retry_Intvl     "30" ;
Call_Back_Delay            ".5" ;
VMWI_Refresh_Intvl        "30" ;
Interdigit_Long_Timer      "10" ;
Interdigit_Short_Timer     "3" ;
CPC_Delay                  "2" ;
CPC_Duration               "0" ;

# *** Vertical Service Activation Codes

Call_Return_Code           "*69" ;
Blind_Transfer_Code        "*98" ;
Call_Back_Act_Code         "*66" ;
Call_Back_Deact_Code       "*86" ;
Cfwd_All_Act_Code          "*72" ;
Cfwd_All_Deact_Code        "*73" ;
Cfwd_Busy_Act_Code         "*90" ;
Cfwd_Busy_Deact_Code       "*91" ;
Cfwd_No_Ans_Act_Code       "*92" ;
Cfwd_No_Ans_Deact_Code     "*93" ;
Cfwd_Last_Act_Code         "*63" ;
Cfwd_Last_Deact_Code       "*83" ;
Block_Last_Act_Code        "*60" ;
Block_Last_Deact_Code      "*80" ;
Accept_Last_Act_Code       "*64" ;
Accept_Last_Deact_Code     "*84" ;
CW_Act_Code                 "*56" ;
CW_Deact_Code               "*57" ;
CW_Per_Call_Act_Code       "*71" ;
CW_Per_Call_Deact_Code     "*70" ;
Block_CID_Act_Code         "*67" ;
Block_CID_Deact_Code       "*68" ;
Block_CID_Per_Call_Act_Code "*81" ;
Block_CID_Per_Call_Deact_Code "*82" ;
Block_ANC_Act_Code         "*77" ;
Block_ANC_Deact_Code       "*87" ;
DND_Act_Code               "*78" ;
DND_Deact_Code             "*79" ;
CID_Act_Code               "*65" ;
CID_Deact_Code             "*85" ;
CWCID_Act_Code             "*25" ;
CWCID_Deact_Code           "*45" ;

```



```

Dist_Ring_Act_Code          "*26" ;
Dist_Ring_Deact_Code        "*46" ;
Speed_Dial_Act_Code         "*74" ;
Secure_All_Call_Act_Code    "*16" ;
Secure_No_Call_Act_Code     "*17" ;
Secure_One_Call_Act_Code    "*18" ;
Secure_One_Call_Deact_Code  "*19" ;
Referral_Services_Codes    "" ;
Feature_Dial_Services_Codes "" ;

# *** Outbound Call Codec Selection Codes

Prefer_G711u_Code           "*017110" ;
Force_G711u_Code            "*027110" ;
Prefer_G711a_Code           "*017111" ;
Force_G711a_Code            "*027111" ;
Prefer_G723_Code            "*01723" ;
Force_G723_Code             "*02723" ;
Prefer_G726r16_Code         "*0172616" ;
Force_G726r16_Code          "*0272616" ;
Prefer_G726r24_Code         "*0172624" ;
Force_G726r24_Code          "*0272624" ;
Prefer_G726r32_Code         "*0172632" ;
Force_G726r32_Code          "*0272632" ;
Prefer_G726r40_Code         "*0172640" ;
Force_G726r40_Code          "*0272640" ;
Prefer_G729a_Code           "*01729" ;
Force_G729a_Code            "*02729" ;

# *** Miscellaneous

Set_Local_Date_(mm/dd)      "" ;
Set_Local_Time_(HH/mm)     "" ;
Time_Zone                    "GMT-07:00" ; # options: GMT-12:00/
    GMT-11:00/GMT-10:00/GMT-09:00/GMT-08:00/GMT-07:00/GMT-06:00/GMT-05:00/
    GMT-04:00/GMT-03:30/GMT-03:00/GMT-02:00/GMT-01:00/GMT/GMT+01:00/
    GMT+02:00/GMT+03:00/GMT+03:30/GMT+04:00/GMT+05:00/GMT+05:30/GMT+05:45/
    GMT+06:00/GMT+06:30/GMT+07:00/GMT+08:00/GMT+09:00/GMT+09:30/GMT+10:00/
    GMT+11:00/GMT+12:00/GMT+13:00
FXS_Port_Impedance          "600" ; # options: 600/900/600+2.16uF/
    900+2.16uF/270+750||150nF/220+820||120nF/220+820||115nF/370+620||310nF
FXS_Port_Input_Gain         "-3" ;
FXS_Port_Output_Gain        "-3" ;
DTMF_Playback_Level         "-16" ;
DTMF_Playback_Length        ".1" ;
Detect_ABCD                  "Yes" ;
Playback_ABCD                "Yes" ;
Caller_ID_Method             "Bellcore(N.Amer,China)" ; # options:
    Bellcore(N.Amer,China)/DTMF(Finland,Sweden)/DTMF(Denmark)/ETSI DTMF/
    ETSI DTMF With PR/ETSI DTMF After Ring/ETSI FSK/ETSI FSK With PR(UK)
FXS_Port_Power_Limit        "3" ; # options: 1/2/3/4/5/6/7/8
Protect_IVR_FactoryReset     "No" ;

```

9. Acronyms

A/D	Analog To Digital Converter
ANC	Anonymous Call
B2BUA	Back to Back User Agent
Bool	Boolean Values. Specified as "yes" and "no", or "1" and "0" in the profile
CA	Certificate Authority
CAS	CPE Alert Signal
CDR	Call Detail Record
CID	Caller ID

CIDCW	Call Waiting Caller ID
CNG	Comfort Noise Generation
CPC	Calling Party Control
CPE	Customer Premises Equipment
CWCID	Call Waiting Caller ID
CWT	Call Waiting Tone
D/A	Digital to Analog Converter
dB	decibel
dBm	dB with respect to 1 milliwatt
DHCP	Dynamic Host Configuration Protocol
DNS	Domain Name Server
DRAM	Dynamic Random Access Memory
DSL	Digital Subscriber Loop
DSP	Digital Signal Processor
DTAS	Data Terminal Alert Signal (same as CAS)
DTMF	Dual Tone Multiple Frequency
ETSI	European Telecommunication Standard
FQDN	Fully Qualified Domain Name
FSK	Frequency Shift Keying
FXS	Foreign eXchange Station
GW	Gateway
ITU	International Telecommunication Union
HTML	Hypertext Markup Language
HTTP	Hypertext Transfer Protocol
HTTPS	HTTP over SSL
ICMP	Internet Control Message Protocol
IGMP	Internet Group Management Protocol
ILEC	Incumbent Local Exchange Carrier
IP	Internet Protocol
ISP	Internet Service Provider
ITSP	IP Telephony Service Provider
IVR	Interactive Voice Response
LAN	Local Area Network
LBR	Low Bit Rate
LBRC	Low Bit Rate Codec
MC	Mini-Certificate
MGCP	Media Gateway Control Protocol
MOH	Music On Hold
MOS	Mean Opinion Score (1-5, the higher the better)
ms	Millisecond
MSA	Music Source Adaptor
MWI	Message Waiting Indication
OSI	Open Switching Interval
PCB	Printed Circuit Board
PR	Polarity Reversal
PS	Provisioning Server
PSQM	Perceptual Speech Quality Measurement (1-5, the lower the better)
PSTN	Public Switched Telephone Network
NAT	Network Address Translation
OOB	Out-of-band
REQT	(SIP) Request Message
RESP	(SIP) Response Message
RSC	(SIP) Response Status Code, such as 404, 302, 600
RTP	Real Time Protocol

RTT	Round Trip Time
SAS	Streaming Audio Server
SDP	Session Description Protocol
SDRAM	Synchronous DRAM
sec	seconds
SIP	Session Initiation Protocol
SLIC	Subscriber Line Interface Circuit
SP	Service Provider
PAP2	Phone Adaptor Ports 2 (Linksys Phone Adaptor)
SSL	Secure Socket Layer
TFTP	Trivial File Transfer Protocol
TCP	Transmission Control Protocol
UA	User Agent
uC	Micro-controller
UDP	User Datagram Protocol
URL	Uniform Resource Locator
VM	Voice Mail
VMWI	Visual Message Waiting Indication/Indicator
VQ	Voice Quality
WAN	Wide Area Network
XML	Extensible Markup Language

10. Glossary

ACD (Automatic Call Distribution): A switching system designed to allocate incoming calls to certain positions or agents in the order received and to hold calls not ready to be handled (often with a recorded announcement).

Area Code: A 3-digit code used in North America to identify a specific geographic telephone location. The first digit can be any number between 2 and 9. The second and third digits can be any number.

Billing Increment: The division by which the call is rounded. In the field it is common to see full-minute billing on the local invoice while 6-second rounding is the choice of most long-distance providers that bill their customers directly.

Blocked Calls: Caused by an insufficient network facility that does not have enough lines to allow calls to reach a given destination. May also pertain to a call from an originating number that is blocked by the receiving telephone number.

Bundled Service: Offering various services as a complete package.

Call Completion: The point at which a dialed number is answered.

Call Termination: The point at which a call is disconnected.

CDR (Call Detail Records): A software program attached to a VoIP/telephone system that records information about the telephone number's activity.

Carrier's Carrier: Companies that build fiber optic and microwave networks primarily selling to resellers and carriers. Their main focus is on the wholesale and not the retail market.

Casual Access: Casual Access is when customers choose not to use their primary carriers to process the long-distance call being made. The customer dials the carrier's 101XXXX number.

CO (Central Office): Switching center for the local exchange carrier.

Centrex: This service is offered by the LEC to the end user. The feature-rich Centrex line offers the same features and benefits as a PBX to a customer without the capital investment or maintenance charges. The LEC charges a monthly fee to the customer, who must agree to sign a term agreement.

Circuits: The communication path(s) that carry calls between two points on a network.

Customer Premise Equipment: The only part of the telecommunications system that the customer comes into direct contact with. Example of such pieces of equipment are: telephones, key systems, PBXs, voicemail systems and call accounting systems as well as wiring telephone jacks. The standard for this equipment is set by the FCC, and the equipment is supplied by an interconnect company.

Dedicated Access: Customers have direct access to the long-distance provider via a special circuit (T1 or private lines). The circuit is hardwired from the customer site to the POP and does not pass through the LEC switch. The dial tone is provided from the long-distance carrier.

Dedicated Access Line (DAL): Provided by the local exchange carrier. An access line from the customer's telephone equipment directly to the long-distance company's switch or POP.

Demarcation Point: This is where the LEC's ownership and responsibility (wiring, equipment) ends and the customer's responsibilities begin.

Direct Inward Dialing (DID): Allows an incoming call to bypass the attendant and ring directly to an extension. Available on most PBX systems and a feature of Centrex service.

Dual Tone Multifrequency (DTMF): Better known as the push button keypad. DTMF replaces dial pulses with electronically produced tones for network signaling.

Enhanced Service: Services that are provided in addition to basic long distance and accessed by way of a touchtone phone through a series of menus.

Exchange Code (NXX): The first three digits of a phone number.

Flat-rate Pricing: The customer is charged one rate (sometimes two rates, one for peak and one for off-peak) rather than a mileage-sensitive program rate.

IXC (Interexchange Carrier): A long-distance provider that maintains its own switching equipment.

IVR (Interactive Voice Response): Provides mechanism for information to be stored and retrieved using voice and a touchtone telephone.

Local Loop: The local telephone company provides the transmission facility from the customer to the telephone company's office, which is engineered to carry voice and/or data.

North American Numbering Plan (NANP): How we identify telephone numbers in North America. We can identify the telephone number based on their three separate components (NPA) (NXX) (XXXX).

PIN (Personal Identification Code): A customer calling/billing code for prepaid and pay-as-you-go calling cards.

Private Branch Exchange: Advanced phone system commonly used by the medium to larger customer. It allows the customer to perform a variety of in-house routing (inside calling). The dial tone that is heard when the customer picks up the phone is an internal dial tone.

SS7 (System Signaling Number 7): Technology used by large carriers to increase the reliability and speed of transmission between switches.

Switch (Switching): Equipment that connects and routes calls and provides other interim functions such as least cost routing, IVR, and voicemail. It performs the "traffic cop" function of telecommunications via automated management decisions.

Touchtone (DTMF): The tone recognized by a push button (touchtone) telephone.

Unified Messaging: Platform that lets users send, receive, and manage all email, voice, and fax messages from any telephone, PC, or information device.

Voice Mail: A system that allows storage and retrieval of voice messages through voicemail boxes.

